



Purchasing Department

140 Stonewall Avenue West, Ste 204
Fayetteville, GA 30214
Phone: 770-305-5420
www.fayettedcountyga.gov

May 29, 2018

Subject: Invitation to Bid #1520-B: Animal Shelter Sewer Project

Gentlemen/Ladies:

Fayette County, Georgia is seeking bids from qualified contractors for abandoning, converting and then installing a new sewer force main, in accordance with the information and specifications contained herein.

A mandatory pre-bid conference will be held at 1:00pm, Thursday, June 14, 2018, at the Fayette County Animal Shelter, 1262 Highway 74 South in Peachtree City, GA 30269. All companies and interested parties are invited and strongly urged to attend. This will be the opportunity to take measurements, pictures, voice all questions, concerns and comments about this Invitation to Bid and have them addressed.

Questions concerning this invitation to bid should be addressed to Trina Barwicks, Contract Administrator in writing via email to tbarwicks@fayettedcountyga.gov or fax to (770) 719-5515. Questions will be accepted until 3:00 pm, Wednesday, June 20, 2018.

The Purchasing Department office hours are Monday through Friday 8:00am to 5:00pm excluding holidays. The office telephone number is (770) 305-5420.

Bids will be received at the address below until 3:00pm, Wednesday, June 27, 2018 in the Purchasing Department, Suite 204. Bids will be opened at that time. Bids must be signed to be considered. Late bids will not be considered. Faxed or emailed bids will not be considered.

Fayette County Purchasing Department
140 Stonewall Avenue West, Suite 204
Fayetteville, Georgia 30214

Bid Number: 1520-B
Bid Name: Animal Shelter Sewer Project

Your bid should be on the pricing sheet included herein. All prices shall be F.O.B. Destination, Fayette County. Be sure to include the **bid number** and **bid name** along with your company's name and address on the **sealed** envelope in which the bid is returned.

If you downloaded this Invitation to Bid from the county's website, it will be your responsibility to check the website for any addenda that might be issued for this solicitation. The county cannot not be responsible for a bidder not receiving information provided in any addenda.

Sincerely,

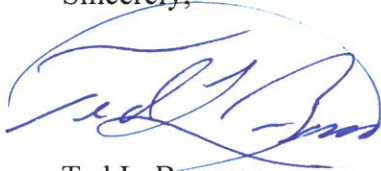
A handwritten signature in blue ink, appearing to read "Ted L. Burgess", is written over a faint, light blue circular stamp or watermark.

Ted L. Burgess
Director of Purchasing

TLB/tcb

GENERAL TERMS AND CONDITIONS

1. **Definitions:** The term “contractor” as used herein and elsewhere in these specifications shall be used synonymously with the term “successful bidder.” The term “county” shall mean Fayette County, Georgia.
2. **Bid is Offer to Contract:** Each bid constitutes an offer to become legally bound to a contract with the county, incorporating the invitation to bid and the bidder’s bid. The binding offer includes compliance with all terms, conditions, special conditions, specifications, and requirements stated in the invitation to bid, except to the extent that a bidder takes written exception to such provisions. All such terms, conditions, special conditions, specifications, and requirements will form the basis of the contract. The bidder should take care to answer all questions and provide all requested information, and to note any exceptions in the bid submission. Failure to observe any of the instructions or conditions in this invitation to bid may result in rejection of the bid.
3. **Binding Offer:** Each bid shall constitute a firm offer that is binding for sixty (60) days from the date of the bid opening, unless the bidder takes exception to this provision in writing.
4. **Bidder’s Questions:** The Fayette County Purchasing Department must receive questions about this invitation to bid in writing at least six days before the scheduled bid opening, excluding Saturdays, Sundays, and holidays. The county will post answers to questions and/or other information concerning the invitation to bid in the form of an addendum on the county’s website at http://www.fayettecountyga.gov/purchasing/bids_and_proposals.asp. It is the responsibility of the prospective bidder to check the website for any addenda issued for this invitation to bid.
5. **References:** Include with your bid a list of three (3) jobs that your company has done that are of the same or similar nature to the work described in this invitation to bid, on the form provided. Include all information as requested on the form.
6. **Bid Submission:** Submit your bid, along with any addenda issued by the county, in a sealed opaque envelope with the following information written on the outside of the envelope:
 - a. The bidder’s company name,
 - b. The bid number, which is #1520-B, and
 - c. The “reference” which identifies the bid, which is “**Animal Shelter Sewer Project**”.

Mail or deliver one (1) unbound original bid (paperclip or binder clip acceptable, no staples), signed in ink by a company official authorized to make a legal and binding offer, to:

Fayette County Georgia
Purchasing Department
140 Stonewall Avenue West, Suite 204
Fayetteville, GA 30214

Attention: Contracts Administrator

You may submit bids in person, by U.S. mail, or by a commercial carrier. Do not submit bids by facsimile, e-mail, or other electronic means. Once submitted, all bids become the property of Fayette County.

7. **Bid Preparation Costs:** The bidder shall bear all costs associated with preparing the bid.
8. **Late Bids:** Bids not received by the time and date of the scheduled bid opening will not be considered, unless the delay is a result of action or inaction by the county.
9. **More than One Bid:** Do not submit alternate bids or options, unless requested or authorized by the county in the Invitation to Bid. If a responder submits more than one bid without being requested or authorized to do so, the county may disqualify the bids from that responder, at the county's option.
10. **Bid Corrections or Withdrawals:** The bidder may correct a mistake, or withdraw a bid, before the bid opening by sending written notification to the Director of Purchasing. Bids may be withdrawn after the bid opening only with written authorization from the Director of Purchasing.
11. **Defects or Irregularities in Bids:** The county reserves the right to waive any defect or irregularity in any bid received. In case of an error in extension of prices or totals in the bid, the unit prices shall govern.
12. **Quantities are Estimates:** Quantities listed herein are estimates for the period specified. This will be an indefinite-quantity type contract, with county requirements fulfilled on an "as ordered" basis. No guarantee to purchase the amounts shown is intended or implied. The county reserves the right to order larger or smaller quantities at the prices stated in the bid of the successful bidder.
13. **Brand Name:** If items in this invitation for bid have been identified, described or referenced by a brand name or trade name description, such identification is intended to be descriptive, but not restrictive and is to indicate the quality and characteristics of products that may be offered. Alternative products may be considered for award if clearly identified in the bid. Items offered must meet required specifications and must be of a quality which will adequately serve the use and purpose for which intended.
14. **Bidder Substitutions:** Bidders offering substitutions or deviations from specifications stated in the invitation to bid, shall list such substitutions or deviations on the "Exceptions to Specifications" sheet provided, or on a separate sheet to be submitted with the bid. The absence of such list shall indicate that the bidder has taken no exception to the specifications. The evaluation of bids and the determination as to equality and acceptability of products or services offered shall be the responsibility of the county.
15. **Samples:** When the county requires samples as part of the bid and vendor selection process, bidders must provide requested samples within the time allotted, and at no cost to the county unless otherwise specified. Any goods provided under contract shall conform to the sample submitted. The county will return samples only at the bidder's request, and at the bidder's expense, if they are not destroyed by testing.
16. **Non-Collusion:** By responding to this invitation to bid, the bidder represents that the bid is not made in connection with any competing bidder, supplier, or service provider submitting a separate response to this invitation to bid, and is in all respects fair and without collusion or fraud.
17. **Bid Evaluation:** Award will be made to the lowest responsive, responsible bidder, taking into consideration payment terms, vendor qualifications and experience, quality, references, any exceptions listed, and/or other factors deemed relevant in making the award. The county may make such investigation as it deems necessary to determine the ability of the bidder to perform, and the bidder shall furnish to the county all information and data for this purpose as the county may request. The county reserves the right to reject any bid item, any bid, or all bids, and to re-advertise for bids.

18. **Discounts:** Cash discounts offered will be a consideration in awarding the bid, but only if they give the county at least 15 days from receipt of invoice to pay. For taking discounts, time will be computed from the date of acceptance at destination or the date a correct invoice is received, whichever is the later date. Payment is deemed made, for the purpose of earning the discount, on the date of the check. For payment of full invoice price, minimum terms of net 30 are preferred.
19. **Trade Secrets - Confidentiality:** If any person or entity submits a bid or proposal that contains trade secrets, an affidavit shall be included with the bid or proposal. The affidavit shall declare the specific included information which constitutes trade secrets. Any trade secrets must be either (1) placed in a separate envelope, clearly identified and marked as such, or (2) at a minimum, marked in the affidavit or an attached document explaining exactly where such information is, and otherwise marked, highlighted, or made plainly visible. See O.C.G.A. § 50-18-72 (A)(34).
20. **Trade Secrets – Internal Use:** In submitting a bid, the bidder agrees that the county may reveal any trade secret materials contained in the bid to all county staff and officials involved in the selection process, and to any outside consultant or other third parties who may assist in the selection process. The bidder agrees to hold harmless the county and each of its officers, employees, and agents from all costs, damages, and expenses incurred in connection with refusing to disclose any material which the bidder has designated as a trade secret.
21. **Ethics – Disclosure of Relationships:** Before a proposed contract in excess of \$10,000.00 is recommended for award to the Board of Commissioners or the County Administrator, or before the County renews, extends, or otherwise modifies a contract after it has been awarded, the contractor must disclose certain relationships with any County Commissioner or County Official, or their spouse, mother, father, grandparent, brother, sister, son or daughter related by blood, adoption, or marriage (including in-laws). A relationship that must be reported exists if any of these individuals is a director, officer, partner, or employee, or has a substantial financial interest in the business, as described in Fayette County Ordinance Chapter 2, Article IV, Division 3 (Code of Ethics).

If such relationship exists between your company and any individual mentioned above, relevant information must be presented in the form of a written letter to the Director of Purchasing. You must include the letter with any bid, proposal, or price bid you submit to the Purchasing Department.

In the event that a contractor fails to comply with this requirement, the County will take action as appropriate to the situation, which may include actions up to and including rejection of the bid or offer, cancellation of the contract in question, or debarment or suspension from award of a County contract for a period of up to three years.
22. **Contract Execution & Notice to Proceed:** After the Board of Commissioners makes an award, all required documents are received by the county, and the contract is fully executed with signature of both parties, the county will issue a written Notice to Proceed. The county shall not be liable for payment of any work done or any costs incurred by any bidder prior to the county issuing the Notice to Proceed.
23. **Unavailability of Funds:** This contract will terminate immediately and absolutely at such time as appropriated and otherwise unobligated funds are no longer available to satisfy the obligations of the county under the contract.

24. **Insurance:** The successful bidder shall procure and maintain the following insurance, to be in effect throughout the term of the contract, in at least the amounts and limits as follows:
- a. **General Liability Insurance:** \$1,000,000 combined single limit per occurrence, including bodily and personal injury, destruction of property, and contractual liability.
 - b. **Automobile Liability Insurance:** \$1,000,000 combined single limit each occurrence, including bodily injury and property damage liability.
 - c. **Worker's Compensation & Employer's Liability Insurance:** Workers Compensation as required by Georgia statute.
 - d. **Builder's "All Risk" Insurance:** In the event the contractor is performing construction services under the contract, contractor shall procure and maintain "all-risk" builder's insurance, providing coverage for the work performed under the contract, and the materials, equipment or other items incorporated therein, while the same are located at the construction site, stored off-site, or at the place of manufacture. The policy limit shall be at least 100% of the value of the contract, including any additional costs which are normally insured under such policy.

Before a contract with the successful bidder is executed, the successful bidder shall provide Certificates of Insurance for all required coverage. The successful offeror can provide the Certificate of Insurance after award of the contract, but must be provided prior to execution of the contract document by both parties. The certificate shall list an additional insured as follows:

Fayette County, Georgia
140 Stonewall Avenue West
Fayetteville, GA 30214

25. **Bid Bond:** You must include a bid bond with your bid, equal to five percent (5%) of the total amount bid. Bid bonds shall be provided by a surety which appears on Georgia's list of approved sureties administered by the State Insurance Commissioner, or the U.S. Treasury's list of approved bond sureties (Circular 570).
26. **Performance and Payment Bonds:** Prior to execution of a contract, the successful bidder shall submit performance and payment bonds each equal to 100 percent of the contract value, provided by a surety which appears on Georgia's list of approved sureties administered by the State Insurance Commissioner, or the U.S. Treasury's list of approved bond sureties (Circular 570).
27. **Unauthorized Performance:** The County will not compensate the contractor for work performed unless the work is authorized under the contract, as initially executed or as amended.
28. **Assignment of Contract:** Assignment of any contract resulting from this invitation to bid will not be authorized, except with express written authorization from the County.

29. **Indemnification:** The contractor shall defend and indemnify the county and all its officers, agents and employees against any suits, actions, or other claims brought on account of any injuries or damages to any person, persons, or property resulting from any negligent act or fault of the contractor, or of any agent, employee, subcontractor or supplier in the performance of any contract which may be awarded. The contractor shall pay any judgment with cost which may be obtained against the county growing out of such injury or damages.
30. **Severability:** The invalidity of one or more of the phrases, sentences, clauses or sections contained in the contract shall not affect the validity of the remaining portion of the contract. If any provision of the contract is held to be unenforceable, then both parties shall be relieved of all obligations arising under such provision to the extent that the provision is unenforceable. In such case, the contract shall be deemed amended to the extent necessary to make it enforceable while preserving its intent.
31. **Delivery Failures:** If the contractor fails to deliver contracted goods or services within the time specified in the contract, or fails to replace rejected items in a timely manner, the county shall have authority to make open-market purchases of comparable goods or services. The county shall have the right to invoice the contractor for any excess expenses incurred, or deduct such amount from monies owed the contractor. Such purchases shall be deducted from contracted quantities.
32. **Inspection and Acceptance of Deliveries:** The county reserves the right to inspect all goods and products delivered. The county will decide whether to accept or reject items delivered. The inspection shall be conclusive except with respect to latent defects, fraud, or such gross mistakes as shall amount to fraud. Final inspection resulting in acceptance or rejection of the products will be made as soon as practicable, but failure to inspect shall not be construed as a waiver by the county to claim reimbursement or damages for such products which are later found to be in non-conformance with specifications. Should public necessity demand it, the county reserves the right to use or consume articles delivered which are substandard in quality, subject to an adjustment in price to be determined by the Purchasing Director.
33. **Termination for Cause:** The County may terminate the contract for cause by sending written notice to the contractor of the contractor's default in the performance of any term of this agreement. Termination shall be without prejudice to any of the county's rights or remedies by law.
34. **Termination for Convenience:** The County may terminate the contract for its convenience at any time with 10 days' written notice to the contractor. In the event of termination for convenience, the county will pay the contractor for services performed. The county will compensate partially completed performance based upon a signed statement of completion submitted by the contractor, which shall itemize each element of performance completed.
35. **Force Majeure:** Neither party shall be deemed to be in breach of the contract to the extent that performance of its obligations is delayed, restricted, or prevented by reason of any act of God, natural disaster, act of government, or any other act or condition beyond the reasonable control of the party in question.
36. **Governing Law:** This agreement shall be governed in accordance with the laws of the State of Georgia. The parties agree to submit to the jurisdiction in Georgia, and further agree that any cause of action arising under this agreement shall be required to be brought in the appropriate venue in Fayette County, Georgia.

Fayette County, Georgia
Checklist of Required Documents

*(Be Sure to Return This Checklist and
the Required Documents in the order listed below)*

ITB #1520-B: ANIMAL SHELTER SEWER PROJECT

Company information – on the form provided _____

Contractor Affidavit under O.C.G.A. § 13-10-91(b)(1) _____

Bid Bond _____

Pricing sheet _____

List of exceptions, if any – on the form provided _____

References – on form provided _____

Addenda, if any _____

COMPANY NAME: _____

Contractor Affidavit under O.C.G.A. § 13-10-91(b)(1)

By executing this affidavit, the undersigned contractor verifies its compliance with O.C.G.A. § 13-10-91, stating affirmatively that the individual, firm or corporation which is engaged in the physical performance of services on behalf of Fayette County, Georgia has registered with, is authorized to use and uses the federal work authorization program commonly known as E-Verify, or any subsequent replacement program, in accordance with the applicable provisions and deadlines established in O.C.G.A. § 13-10-91. Furthermore, the undersigned contractor will continue to use the federal work authorization program throughout the contract period and the undersigned contractor will contract for the physical performance of services in satisfaction of such contract only with subcontractors who present an affidavit to the contractor with the information required by O.C.G.A. § 13-10-91(b). Contractor hereby attests that its federal work authorization user identification number and date of authorization are as follows:

Federal Work Authorization User Identification Number

Date of Authorization

Name of Contractor

ITB #1520-B: ANIMAL SHELTER SEWER PROJECT

Name of Project

FAYETTE COUNTY GEORGIA

Name of Public Employer

I hereby declare under penalty of perjury that the foregoing is true and correct.

Executed on _____, _____, 2018 in (city) _____, (state) _____

Signature of Authorized Officer or Agent

Printed Name and Title of Authorized Officer or Agent

SUBSCRIBED AND SWORN BEFORE ME

ON THIS THE _____ DAY OF _____, 2018.

NOTARY PUBLIC

My Commission Expires:

ITB #1520-B: ANIMAL SHELTER SEWER PROJECT

I. INTRODUCTION & BACKGROUND

Fayette County is seeking bids from qualified contractors for abandoning, converting and then installing a new sewer force main to connect into Peachtree City's Water & Sewer Authority's (PCWSA) sewer system. The existing Animal shelter operates on a septic system with a toggle to redirect waste to either one of two separate drain fields to maintain a functional sewer system for that facility. The septic system drain fields are failing and require us to swap between each field on a monthly basis once the field become saturated.

II. SCOPE OF WORK

1. The successful Contractor shall directional bore the section of force main sewer between Fayette County's property and the existing Peachtree City Water & Sewer Authority manhole located in the right-of-way of Lavender Oasis Road as reflected on the construction plans. The 4" diameter directional bore piping will function as the casing for the 3" diameter force main pipe.
2. The contractor shall grout around pipe casing where it enters the manhole ensure it has a good seal. Contractor is to caulk any gap remaining between the 4" pipe casing and the 3" diameter force main pipe where it enters the manhole.
3. The contractor is responsible for having utilities field located and potholed as necessary to avoid boring through any service lines for the water & sewer service laterals. Contractor is responsible for any repairs to utilities damaged by their operations at no additional cost to the County.
4. The Animal Shelter facility has two (2) existing septic tanks and a wet well. The two septic tanks are located under the existing asphalt pavement and are to be abandoned and closed out as noted in the plans. The influent and effluent pipe within each of these septic tanks is to be connected with a section of new pipe so that sewage will continue to gravity flow through the septic tank after it is abandoned. Upon abandonment of the septic tanks, the existing wet well tank will function as a septic tank with grinder pump.
5. Project design/construction plans show the proposed alignment of the entire force main. Contractor is to determine the alignment that can be achieved with the directional bore while keeping all underground work within the acquired easement area(s).
6. Any unexpected obstacles (rock, etc.) encountered during the directional bore process shall be reported immediately to Fayette County if the contractor finds that underground work can only continue by going outside the acquired easement area.
7. The contractor is responsible for adhering to all specifications including those specifications on the construction plans. Should there be any conflicts between the written specifications and the plan specifications, the more stringent specification(s)

shall prevail. Contractor shall notify Fayette County immediately upon any discovery of such deviations.

8. The Contractor shall be responsible for the removal of all waste generated from this project. Waste materials shall not be buried on site, but shall be taken to an approved landfill.
9. The contractor is responsible for getting all required permits for this project. Contractor shall get with the County's Environmental Health Department to get the required closure inspection on the abandoned septic tanks.
10. Safety on this project is of utmost importance. The Contractors shall be responsible for setting up any required barriers, barricades and/or signage to keep the public out of the work zone areas during construction.
11. The Contractor shall be responsible for getting all material on site, and staging all materials and equipment in designated staging areas approved by the County.
12. The Contractor shall be responsible for all materials, labor, vehicles, tools, equipment, mobilization, fuel, etc. needed to complete the work as contracted.
13. The Contractor shall be responsible for repairing any damage to improvements, infrastructure and landscaping as a result of the contractor or his subs work efforts.
14. Contractor is responsible for backfilling all pipe trenches and seeding and strawing all disturbed areas to establish permanent stabilization per Green Book standards.
15. The Contractor is responsible for the personal conduct of their employees while on county property. Personnel are expected to be professional and courteous at all time. There is a no tobacco policy while on all county property and in county buildings.
16. Contractor shall provide a time line for the project, once the project starts the contractor shall continue to perform all needed work, through completion of the project without extended delays.
17. Fayette County Building Maintenance personnel will perform periodic inspections of the job site as work progresses.
18. Should the inspection determine that work performed is sub-standard and / or not per code, the contractor will be notified immediately of the problem and a "Stop Work Notice" will be issued until the problem is resolved.
19. Should the County elect to go with the ALTERNATE item that involves installing a new manhole structure within the right-of-way of Lavender Oasis, backfill around the new manhole structure is to be a minimum 95% standard proctor.
20. A mandatory pre-bid conference will be held for this project. Questions from contractors shall be submitted by the required deadline as noted on page 1 of this Invitation to Bid.

CONSTRUCTION DRAWINGS FOR FAYETTE COUNTY ANIMAL SHELTER SANITARY SEWER IMPROVEMENTS

Land Lot 29, 6th Land District

FAYETTE COUNTY, GEORGIA

TOTAL SITE AREA- 2.54 Ac.

DISTURBED AREA = 0.03 AC

STATE WATER NOTE:
THESE ARE STATE WATER RIGHTS AND ARE NOT TO BE CONSIDERED AS PART OF THE CONSTRUCTION PERMITS.

WETLANDS NOTE:
BASED UPON FIELD INSPECTIONS AND OBSERVATIONS OF THE PROPERTY AND SUPPORTED BY THE NATIONAL WETLANDS INVENTORY, THERE ARE NO WETLANDS ON THE PROPERTY. THE WETLANDS BOUNDARIES AND INDICATE SERVICE, THERE ARE NO WETLANDS CONTAINED WITHIN THE PROJECT LIMITS OF THE SITE.

WATERSHED NOTE:
THE PROJECT IS LOCATED WITHIN THE FAYETTE COUNTY AND WETLANDS AND ENVIRONMENTAL MANAGEMENT DISTRICT (WATER) CREEK AND IS LOCATED IN THE UPPER ELMT. WATERSHED - 0370000

GENERAL CONSTRUCTION NOTES:

1. FORCE MAIN CONSTRUCTION, FORCE MAIN TIE TO MANHOLE AND INSPECTION/APPRAISALS OF ALL WORK CONCERNING FORCE MAIN TO BE COMPLETED PRIOR TO THE INSTALLATION OF SANITARY SEWER.
2. BEFORE ANY CONSTRUCTION, THE CONTRACTOR SHALL OBTAIN ALL NECESSARY PERMITS AND APPROVALS FROM THE FAYETTE COUNTY ENGINEERING DEPT.
3. THE CONTRACTOR SHALL MAINTAIN ALL EXISTING UTILITIES AND SHALL BE RESPONSIBLE FOR THE PROTECTION OF ALL EXISTING UTILITIES.
4. THE CONTRACTOR SHALL MAINTAIN ALL EXISTING UTILITIES AND SHALL BE RESPONSIBLE FOR THE PROTECTION OF ALL EXISTING UTILITIES.
5. THE CONTRACTOR SHALL MAINTAIN ALL EXISTING UTILITIES AND SHALL BE RESPONSIBLE FOR THE PROTECTION OF ALL EXISTING UTILITIES.
6. THE CONTRACTOR SHALL MAINTAIN ALL EXISTING UTILITIES AND SHALL BE RESPONSIBLE FOR THE PROTECTION OF ALL EXISTING UTILITIES.
7. THE CONTRACTOR SHALL MAINTAIN ALL EXISTING UTILITIES AND SHALL BE RESPONSIBLE FOR THE PROTECTION OF ALL EXISTING UTILITIES.
8. THE CONTRACTOR SHALL MAINTAIN ALL EXISTING UTILITIES AND SHALL BE RESPONSIBLE FOR THE PROTECTION OF ALL EXISTING UTILITIES.
9. THE CONTRACTOR SHALL MAINTAIN ALL EXISTING UTILITIES AND SHALL BE RESPONSIBLE FOR THE PROTECTION OF ALL EXISTING UTILITIES.
10. THE CONTRACTOR SHALL MAINTAIN ALL EXISTING UTILITIES AND SHALL BE RESPONSIBLE FOR THE PROTECTION OF ALL EXISTING UTILITIES.
11. THE CONTRACTOR SHALL MAINTAIN ALL EXISTING UTILITIES AND SHALL BE RESPONSIBLE FOR THE PROTECTION OF ALL EXISTING UTILITIES.
12. THE CONTRACTOR SHALL MAINTAIN ALL EXISTING UTILITIES AND SHALL BE RESPONSIBLE FOR THE PROTECTION OF ALL EXISTING UTILITIES.



(NO SCALE)

CONSTRUCTION ACTIVITY SCHEDULE

| ACTIVITY | DATE OF CONSTRUCTION ACTIVITY |
|---|-------------------------------|
| INITIAL INTERMEDIATE EROSION/SEDIMENT CONTROL | 1 |
| FORMAL CONSTRUCTION AND MANHOLE TIE | 2 |
| PUMP SEPTIC TANK/INSTANT OPERATOR PUMP/PIPER TANK | 3 |
| FINAL STABILIZATION | 4 |
| EROSION CONTROL MAINTENANCE | 5 |
| MANHOLE THROUGHOUT LIFE OF PROJECT | 6 |

GENERAL NOTES:

1. ALL WORK SHALL COMPLY WITH FAYETTE COUNTY, PEACREE CITY, PEACREE CITY WATER AND SEWER AUTHORITY AND STATE OF GEORGIA.
2. THE CONTRACTOR IS TO VERIFY ALL UTILITIES ARE OBTAINED AND ARE READY AVAILABLE PRIOR TO COMMENCEMENT OF ANY WORK. COME BY THE PEACREE CITY WATER AND SEWER AUTHORITY FOR A UTILITY LOCATED AT THE PROJECT SITE.
3. THE CONTRACTOR SHALL MAINTAIN ALL EXISTING UTILITIES AND SHALL BE RESPONSIBLE FOR THE PROTECTION OF ALL EXISTING UTILITIES.
4. THE CONTRACTOR SHALL MAINTAIN ALL EXISTING UTILITIES AND SHALL BE RESPONSIBLE FOR THE PROTECTION OF ALL EXISTING UTILITIES.
5. THE CONTRACTOR SHALL MAINTAIN ALL EXISTING UTILITIES AND SHALL BE RESPONSIBLE FOR THE PROTECTION OF ALL EXISTING UTILITIES.
6. THE CONTRACTOR SHALL MAINTAIN ALL EXISTING UTILITIES AND SHALL BE RESPONSIBLE FOR THE PROTECTION OF ALL EXISTING UTILITIES.
7. THE CONTRACTOR SHALL MAINTAIN ALL EXISTING UTILITIES AND SHALL BE RESPONSIBLE FOR THE PROTECTION OF ALL EXISTING UTILITIES.
8. THE CONTRACTOR SHALL MAINTAIN ALL EXISTING UTILITIES AND SHALL BE RESPONSIBLE FOR THE PROTECTION OF ALL EXISTING UTILITIES.
9. THE CONTRACTOR SHALL MAINTAIN ALL EXISTING UTILITIES AND SHALL BE RESPONSIBLE FOR THE PROTECTION OF ALL EXISTING UTILITIES.
10. THE CONTRACTOR SHALL MAINTAIN ALL EXISTING UTILITIES AND SHALL BE RESPONSIBLE FOR THE PROTECTION OF ALL EXISTING UTILITIES.
11. THE CONTRACTOR SHALL MAINTAIN ALL EXISTING UTILITIES AND SHALL BE RESPONSIBLE FOR THE PROTECTION OF ALL EXISTING UTILITIES.
12. THE CONTRACTOR SHALL MAINTAIN ALL EXISTING UTILITIES AND SHALL BE RESPONSIBLE FOR THE PROTECTION OF ALL EXISTING UTILITIES.

| SHEET | INDEX | DESCRIPTION |
|-------|---|--|
| 1 | COVER SHEET | CONSTRUCTION DRAWINGS, PLAN VIEWS, PROFILE, SEPTIC TANK ABANDONMENT, EROSION CONTROL |
| 2 | CONSTRUCTION DETAILS - ROADS, SANITARY SEWER | |
| 3 | CONSTRUCTION DETAILS - EROSION AND SEDIMENT CONTROL | |
| 4 | | |

REVISION DATES

COVER SHEET

ENGINEERING DEPT.
115 McDonough Road
Fayetteville, Georgia 30215
Phone: (770) 320-6010
Fax: (770) 719-0871
www.fayettecountyga.gov

FAYETTE COUNTY
PUBLIC WORKS DEPARTMENT
April 16, 2018
FAYETTE COUNTY ANIMAL SHELTER
SANITARY SEWER IMPROVEMENTS
FORCE MAIN TO LAVENDER OASIS
LAND LOT 29, 6TH DISTRICT,
PEACREE CITY, FAYETTE COUNTY, GA 1

| COUNTY | STATE | PROJECT NUMBER | TOTAL SHEETS |
|---------|-------|----------------|--------------|
| FAYETTE | GA | 6565F | 4 |

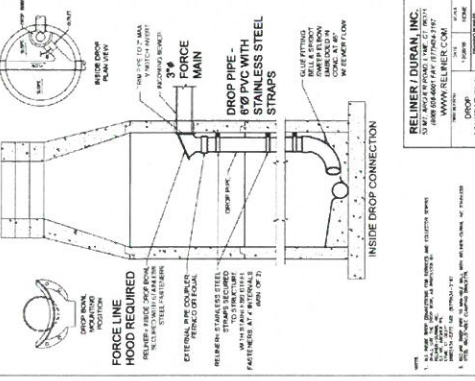
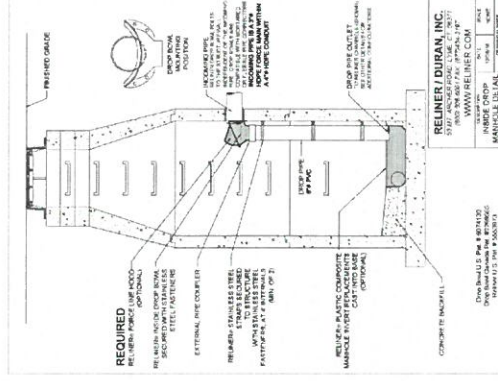
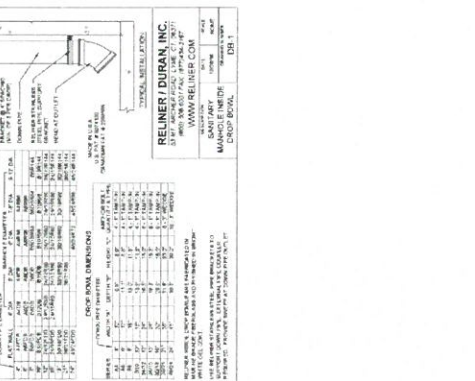
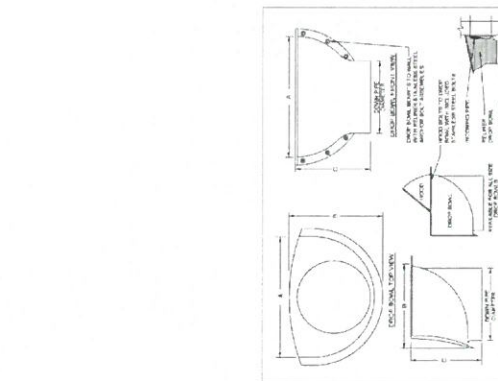
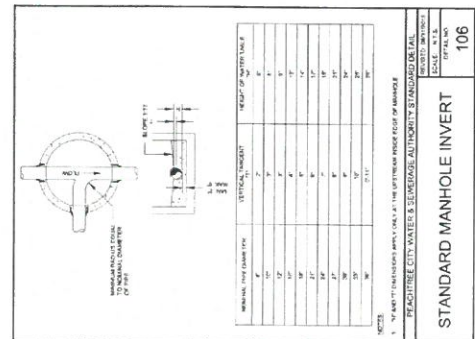
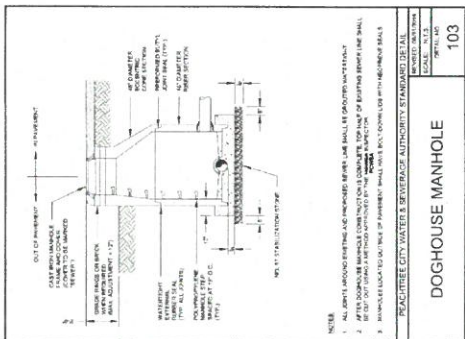
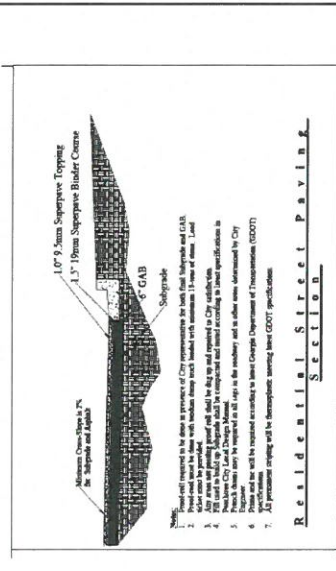
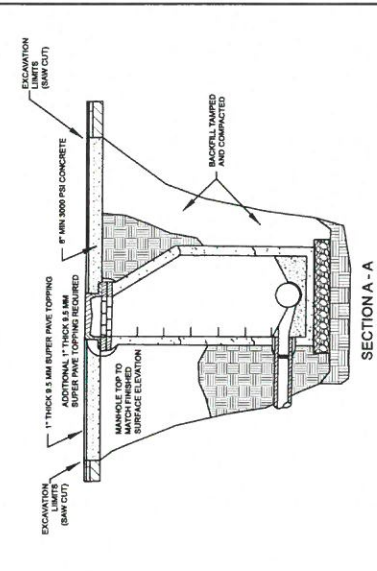
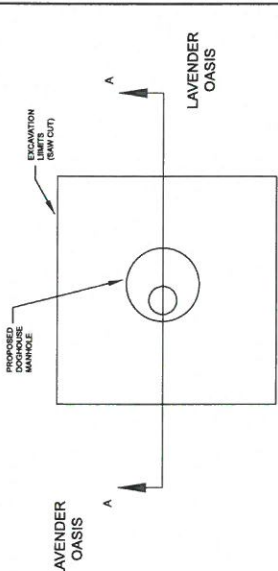

REVISION DATES

REVISION DATES

FAYETTE COUNTY
PUBLIC WORKS DEPARTMENT
April 18, 2018
FAYETTE COUNTY ANIMAL SHELTER
SANITARY SEWER IMPROVEMENTS
FORCE MAIN TO LAVENDER OASIS
LAND LOT 29, 6th DISTRICT,
FAYETTE COUNTY, GA

FAYETTE County
Create Your Story!

ENGINEERING DEPT.
115 McDonough Road
Fayetteville, Georgia 30215
Phone: (770) 320-8010
Fax: (770) 719-4871
www.fayettecountysga.gov

CONSTRUCTION
DETAILS

GEORGIA811
www.Georgia811.com
Have a job? Call before you dig.

**PRICING SHEET –
ITB #1520-B: ANIMAL SHELTER SEWER PROJECT**

| ITEM NO | ITEM DESCRIPTION | QUAN | UNIT | UNIT COST | TOTAL ITEM COST |
|---------|---|------|------|-----------|-----------------|
| 1 | Mobilization | 1 | LS | | |
| 2 | ABANDON EXISTING SEPTIC TANK, Per Detail on Plan Sheet 2, Complete in place and accepted | 2 | EA | | |
| 3 | Trench New 2" Dia HDPE Pipe, Schedule 40, Includes reducer | 1 | LS | | |
| 4 | Directional Bore new 4" Dia HDPE pipe (Casing for 3" force main pipe), Includes Core into existing MH and grouting around pipe to seal | 1 | LS | | |
| 5 | Provide and Install 3" diameter HDPE force main pipe within bored casing | 1 | LS | | |
| 6 | Inside Drop in Manhole, 1'-4' deep drop | 1 | EA | | |
| 7 | Inside Drop in Manhole, 4' - 10' deep drop | 1 | EA | | |
| 8 | Provide & Install Grinder Pump, 1hp, Liberty PRG-Series or equal, Install into Exist. Septic Tank #3, Includes power to pump, Complete-in-Place and Accepted | 1 | LS | | |
| 9 | Disconnect and remove Exist. Drain Field pipe(s) encountered during trenching efforts | 1 | LS | | |
| 10 | Erosion Control – temporary and permanent seed & straw, silt fence, curb inlet filter, construction entrance/exit, etc. | 1 | LS | | |
| 11 | 6" Thick Concrete for Utility/street repair, 3,000psi | 5 | SY | | |
| 12 | 1" thick, 9.5MM Superpave | 5 | SY | | |
| 13 | Allowance – For owner use only to address scope changes | | | | \$10,000.00 |
| | BASE PRICE | | | | |
| | ALTERNATE: Furnish & Install Standard. 4' dia. Doghouse Manhole with cast iron frame & cover, 10' deep, Includes all equipment to excavate, backfill & compact around manhole. | 1 | LS | | |

COMPANY NAME: _____

BID SHEET - CONTINUED
ITB #1520-B: ANIMAL SHELTER SEWER PROJECT

NOTE: All applicable charges shall be included in your prices, e.g., mobilization, materials, equipment, fuel for equipment, labor, and any other charges or fees. No additional charges will be allowed to be added after the quote received by date.

STATE PAYMENT TERMS _____.

STATE TIME NEEDED TO START PROJECT AFTER NOTICE TO PROCEED

_____ DAYS.

STATE TIME NEEDED TO COMPLETE PROJECT AFTER START DATE

_____ DAYS.

SPECIFY LENGTH AND NATURE OF WARRANTY (IF ANY)

COMPANY NAME: _____

ITB #1520-B: ANIMAL SHELTER SEWER PROJECT - REFERENCES

Please list three (3) references of current or very recent customers who can verify the quality of service your company provides. Projects of similar size and scope are required.

REFERENCE ONE

Government/Company Name _____

City _____

Contact Person and Title _____

Phone _____ Contract Period _____

Scope of Work _____

REFERENCE TWO

Government/Company Name _____

City _____

Contact Person and Title _____

Phone _____ Contract Period _____

Scope of Work _____

REFERENCE THREE

Government/Company Name _____

City _____

Contact Person and Title _____

Phone _____ Contract Period _____

Scope of Work _____

COMPANY NAME _____

ITB #1520-B: ANIMAL SHELTER SEWER PROJECT

COMPANY INFORMATION

Company _____

Physical Address of Business _____

Mailing Address (If Different) _____

Authorized Representative _____
(Print or Type)

Authorized Representative _____
(Signature)

Title _____

Email Address: _____

Company Telephone Number: _____ Fax Number: _____

Project Contact Person Name: _____

Email Address for Notification: _____

Office Number: _____ **Cellular Number:** _____