

TABLE OF CONTENTS

FAYETTEVILLE, GA L9-1477

DIVISION 1 - Description of Operation

DIVISION 2 - Filter Control Console:
Ladder Diagrams
Bills of Material
Console Arrangement Drawings

DIVISION 3 - PLC Equipment

DIVISION 4 - Rate Set Station

DIVISION 5 - Digital Indicator

DIVISION 6 - MT-200

DIVISION 7 - Differential Pressure Transmitters:
Effluent Rate of Flow
Loss of Head
Backwash Rate of Flow
Air Scour Rate of Flow

DIVISION 8 - Continuous Level Transmitters:
Filter Level
Influent Level

DIVISION 9 - Flow Tubes
Filter Effluent
Backwash
Air Scour

DIVISION 10 - PLC Code

VIEW - "A"
(SCALE: 1/4"=1")

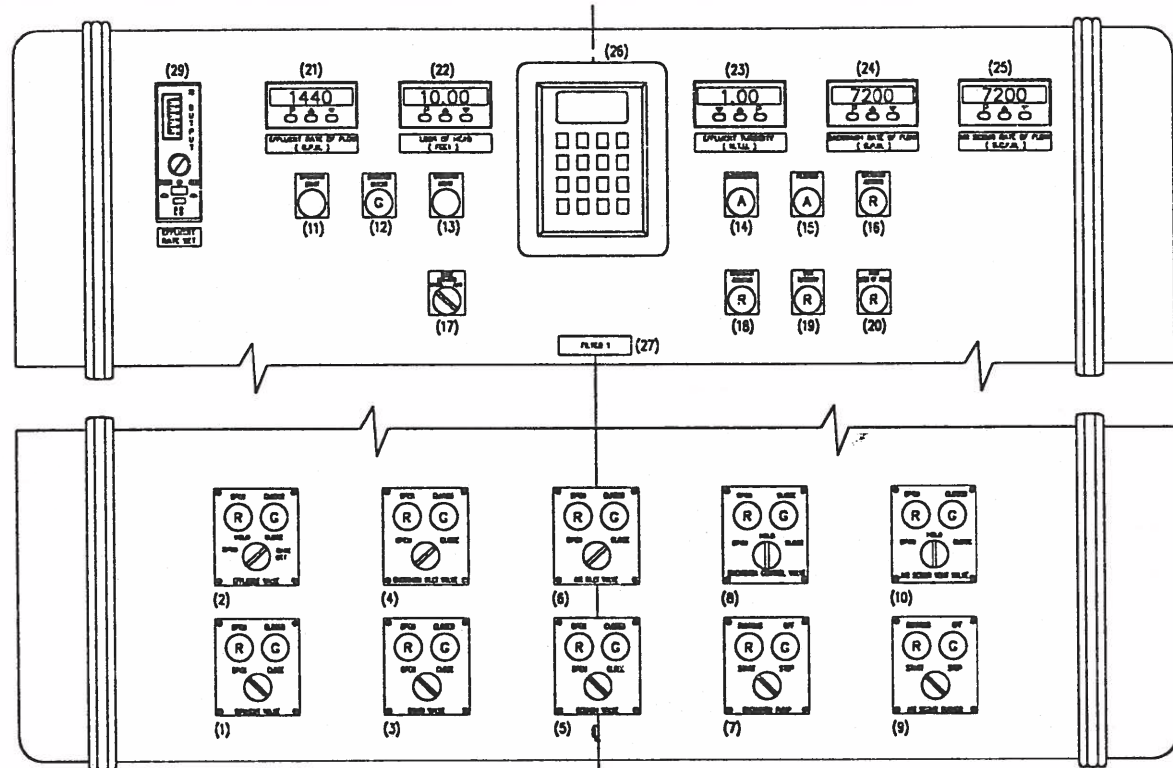

VIEW - "B"
(SCALE: 1/4"=1")

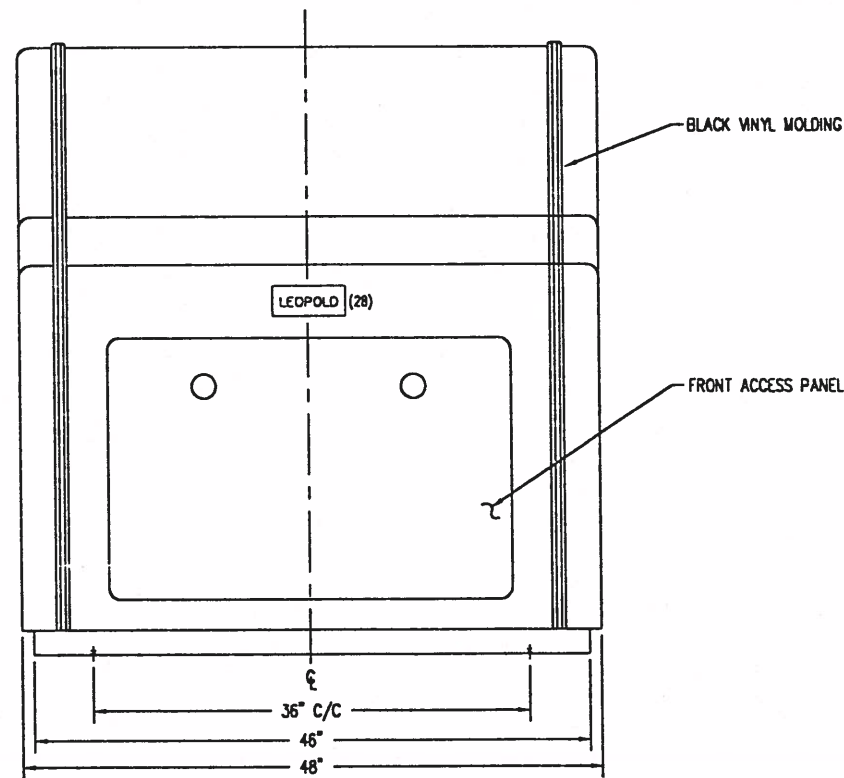

FRONT VIEW
(SCALE: 1/8"=1")

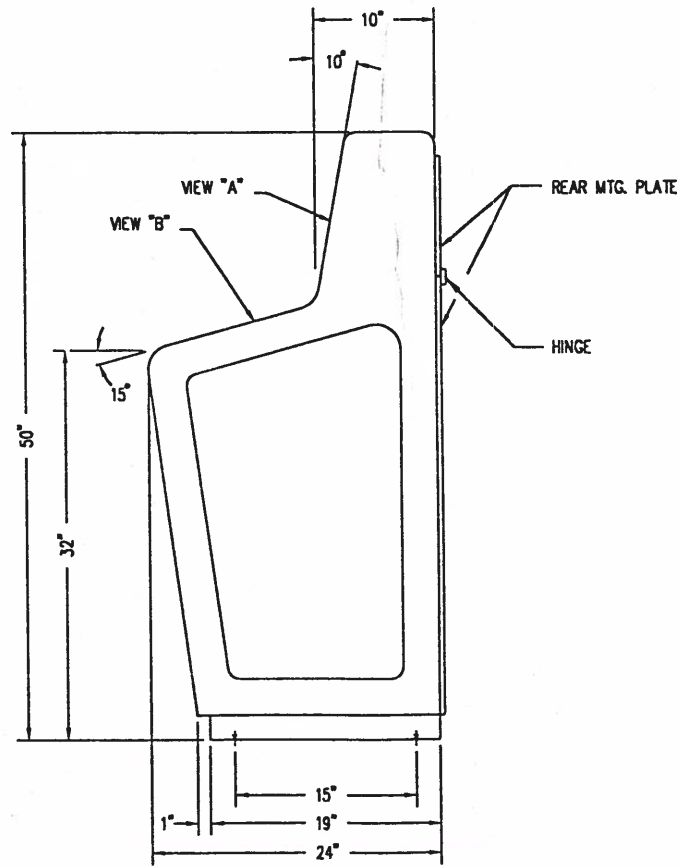

SIDE VIEW
(SCALE: 1/8"=1")

ITEM	NUMBER REQUIRED	DESCRIPTION	NAMEPLATE
LP1	1	CONTROL STATION	INFLUENT VALVE
LP2	1	CONTROL STATION	EFFLUENT VALVE
LP3	1	CONTROL STATION	DRAIN VALVE
LP4	1	CONTROL STATION	BACKWASH INLET VALVE
LP5	1	CONTROL STATION	REWASH VALVE
LP6	1	CONTROL STATION	AIR INLET VALVE
LP7	1	CONTROL STATION	BACKWASH PUMP
LP8	1	CONTROL STATION	BACKWASH CONTROL VALVE
LP9	1	CONTROL STATION	AIR SCOUR BLOWER
LP10	1	CONTROL STATION	AIR SCOUR VENT VALVE
LP11	1	PUSHBUTTON - GREEN FLUSH HEAD	START BACKWASH
LP12	1	ILLUM PUSHBUTTON - GREEN FLUSH HEAD	EXTEND BACKWASH
LP13	1	PUSHBUTTON - RED EXTENDED HEAD	ABORT BACKWASH
LP14	1	PILOT LIGHT	BACKWASHING
LP15	1	PILOT LIGHT	FILTERING
LP16	1	PILOT LIGHT	BACKWASH ABORTED
LP17	1	3 POS. SELECTOR SWITCH	MODE (MANUAL SEMI-AUTO AUTO)
LP18	1	PILOT LIGHT	BACKWASH REQUIRED
LP19	1	PILOT LIGHT	HIGH TURBIDITY
LP20	1	PILOT LIGHT	HIGH LOSS OF HEAD
LP21	1	DIGITAL INDICATOR	EFFLUENT RATE OF FLOW
LP22	1	DIGITAL INDICATOR	LOSS OF HEAD
LP23	1	DIGITAL INDICATOR	EFFLUENT TURBIDITY
LP24	1	DIGITAL INDICATOR	BACKWASH RATE OF FLOW
LP25	1	DIGITAL INDICATOR	AIR SCOUR RATE OF FLOW
LP26	1	OPERATOR INTERFACE	MT200
LP27	6	FILTER NAMEPLATE (1 PER FILTER)	FILTER #1 - FILTER #6
LP28	6	LEOPOLD LOGO (1 PER FILTER)	
LP29	1	RATE SET STATION	EFFLUENT RATE SET

NOTES:

1. CONSOLE MAT'L = FIBERGLASS REINFORCED RESIN
2. CONSOLE COLOR = MATCH THEMEC DELFT BLUE # G803
3. ALL CONNECTIONS FROM CONSOLE TO FIELD LOCATED EQUIPMENT ARE NOT BY LEOPOLD CO.
4. LADDER DIAGRAM DWG. NO. 1477.99.2

<small>THIS DRAWING IS SENT TO YOU SUBJECT TO RETURN UPON DEMAND, AND WITH THE UNDERSTANDING THAT IT IS NOT TO BE REPRODUCED, COPIED OR USED DIRECTLY OR INDIRECTLY, IN ANY WAY DETRIMENTAL TO OUR INTERESTS. ALL PATENT RIGHTS RESERVED.</small>		LEOPOLD WATER & WASTEWATER PRODUCTS	
REVISION 1 2 3	48" FCP FILTER CONTROL CONSOLE UNE "31" FAYETTEVILLE, GA	(6) REQ'D L9-1477	227 S. DUNDON STREET FAYETTEVILLE, GA 30215-1213
DRAWN BY TAZ	CHECKED BY	DATE 5-21-99	SCALE AS NOTED
		DWG NO 1477.99.1	

CUSTOMER POWER*
120 VAC 1Φ 60 HZ 20 A

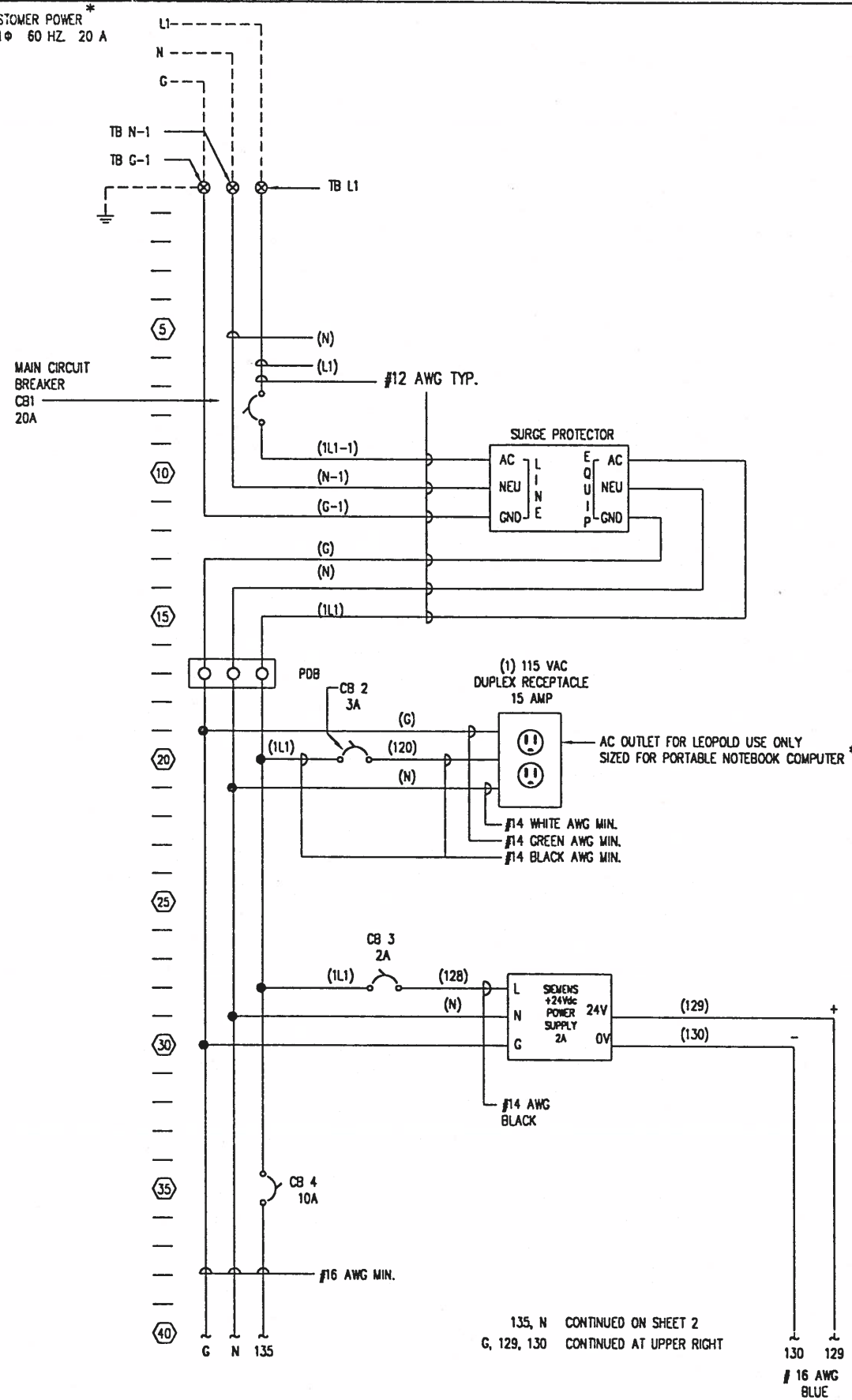

135, N CONTINUED ON SHEET 2
G, 129, 130 CONTINUED AT UPPER RIGHT

- LEGEND:
- = FIELD WIRING
 - = POWER & CONTROL WIRING
 - ⊗ = TERMINAL BLOCK CONNECTION
 - (124) = WIRE NUMBER (TYP.)
 - 10001 = PLC ADDRESS NUMBER (TYP.)

SHOP NOTE:
DO NOT RUN INSTR. SHIELDED WIRES BUNDLED WITH AC, DC, OR ANY CONDUCTING WIRE(S)

CONTINUED FROM LOWER LEFT

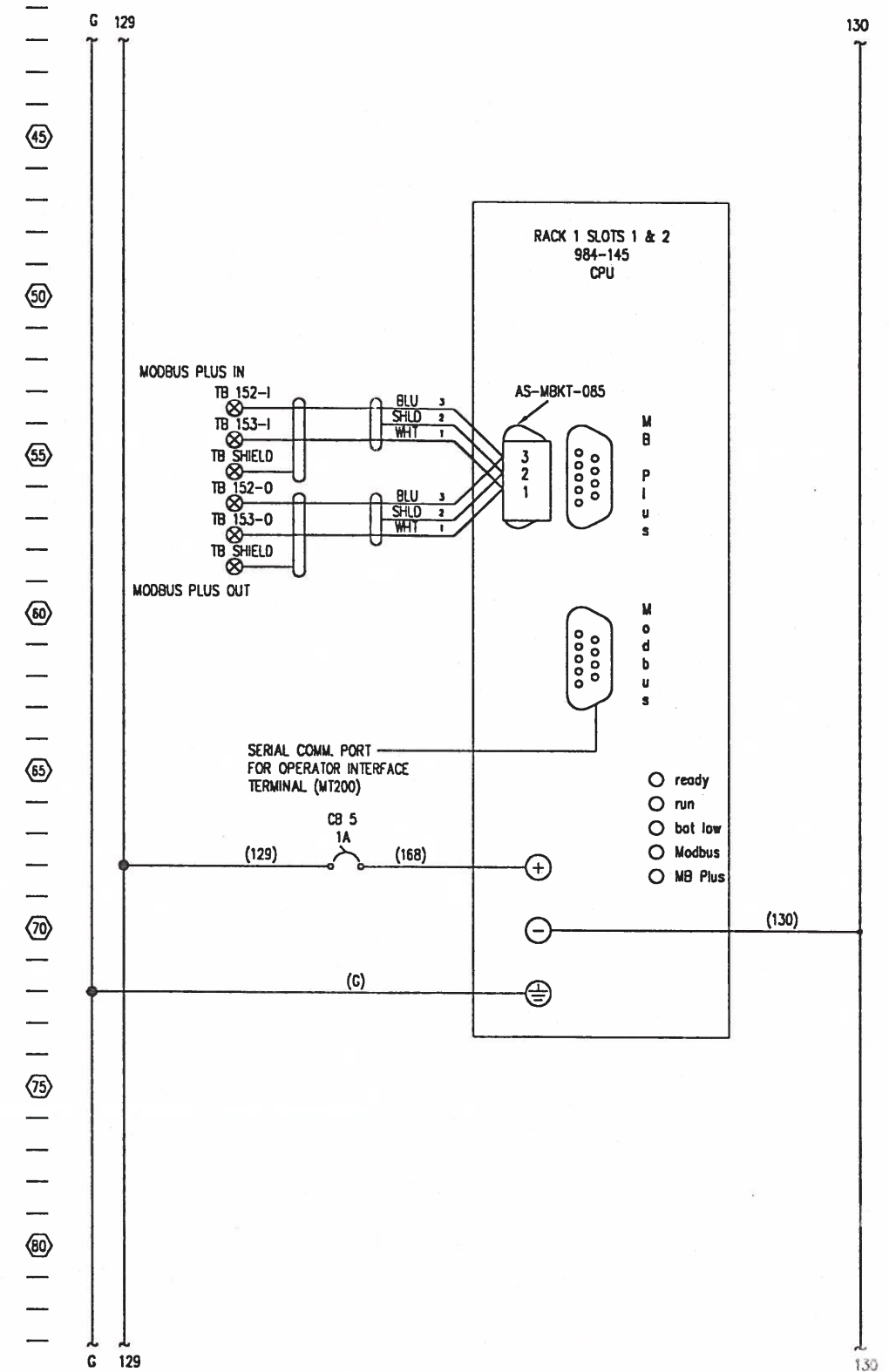

129, 130 CONTINUED ON SHEET 8
G CONTINUED ON SHEET 11

- FOR FILTER CONSOLE ASSY SEE DWG # 1477.99.1
- * INDICATES COMPONENTS NOT SUPPLIED BY LEOPOLD COMPANY
- ▲ INDICATES : 18 AWG. TWISTED SHIELDED PAIR WIRING (ANALOG)
- ALL INTERNAL PANEL WIRING TO BE 16 AWG. EXCEPT DAISY CHAINED HOT, NEUTRAL, & GROUND WIRING TO BE 14 AWG OR AS NOTED.

- ALL WIRES TO BE NUMBERED AT BOTH ENDS WITH PROPER IDENTIFICATION INCLUDING (N) & (SHIELD)
- ALL WIRING TO FIELD DEVICES - NOT BY LEOPOLD

REVISION		FILTER CONTROL LADDER DIAGRAM	
1		LINE #31	(6) REQ'D
2		FAYETTEVILLE, GA	L9-1477
3			
DRAWN BY	CHECKED BY	DATE	SCALE
TAZ		5-21-99	NONE
DWG NO		1477.99.2	
SHEET		9	

287 S. OGDEN STREET ZELIHOPE, PA 16813-1213



CONTINUED FROM SHEET 1

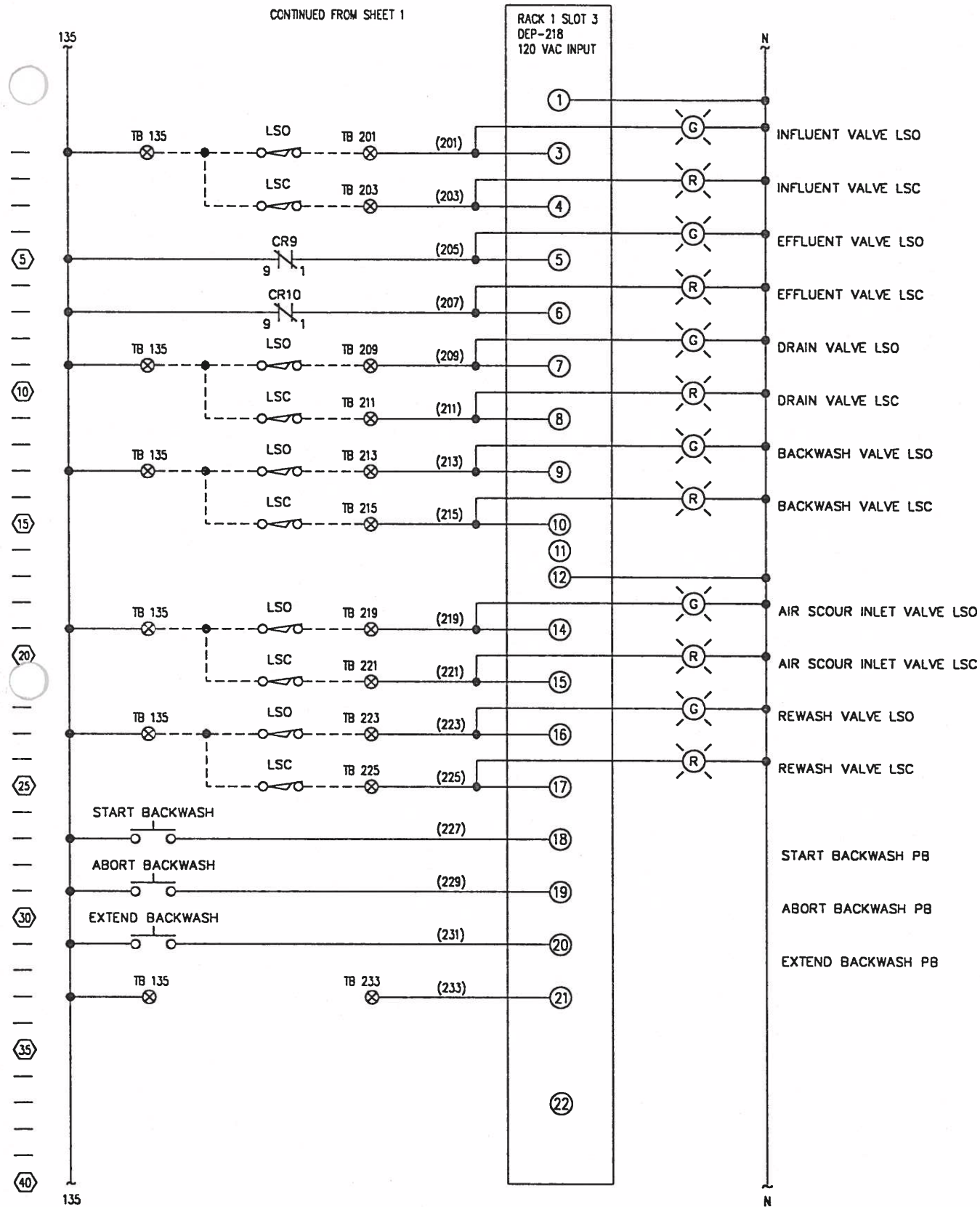

CONTINUED AT UPPER RIGHT

CONTINUED FROM LOWER LEFT

- 10001
- 10002
- 10003
- 10004
- 10005
- 10006
- 10007
- 10008
- 10009
- 10010
- 10011
- 10012
- 10013
- 10014
- 10015
- 10016

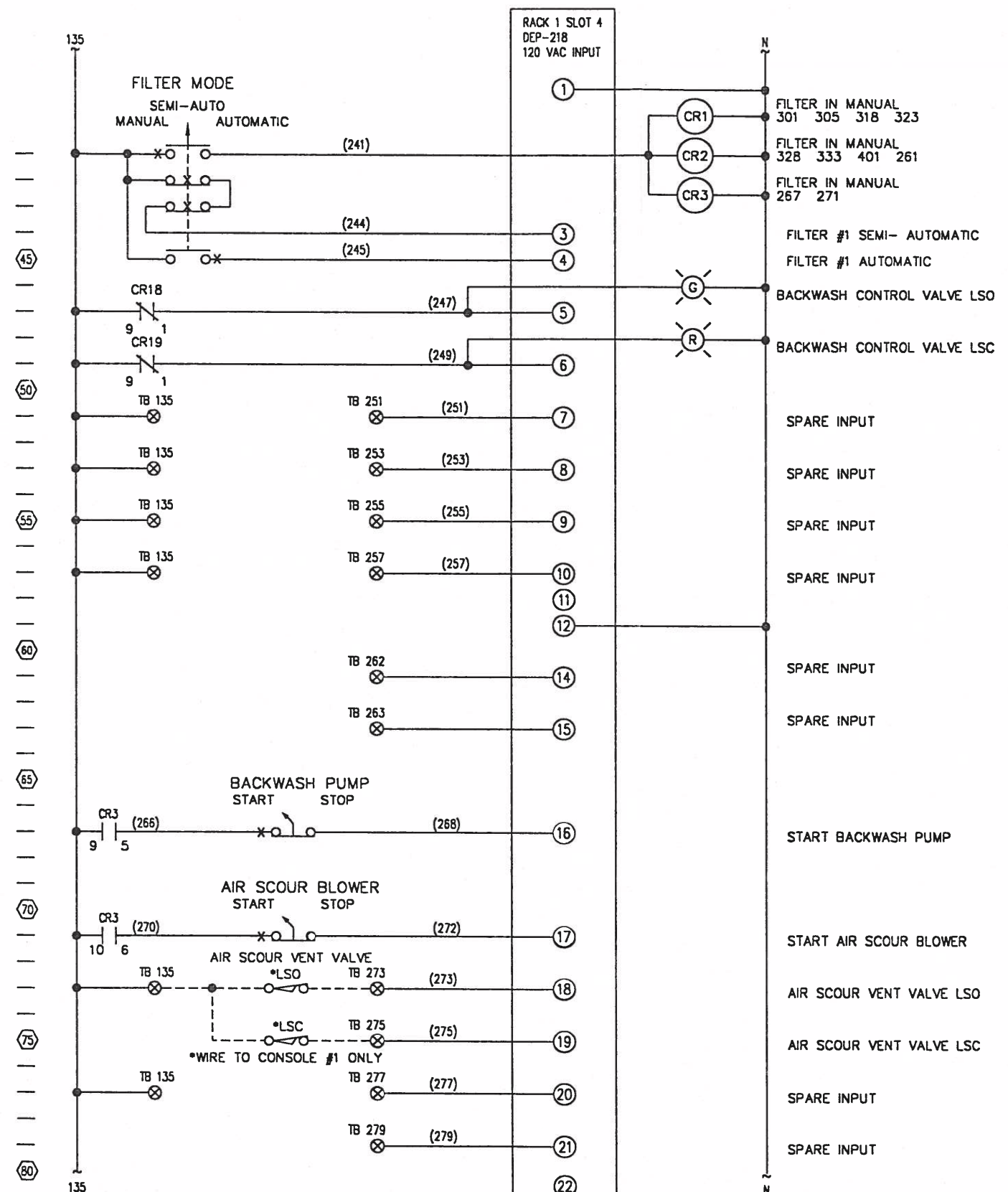

CONTINUED ON SHEET 3

- 10017
- 10018
- 10019
- 10020
- 10021
- 10022
- 10023
- 10024
- 10025
- 10026
- 10027
- 10028
- 10029
- 10030
- 10031
- 10032

NOTES:

1. SEE SHEET 1 FOR GENERAL NOTES
2. * INDICATES COMPONENTS NOT SUPPLIED BY LEOPOLD COMPANY

THIS DRAWING IS SENT TO YOU SUBJECT TO RETURN UPON DEMAND, AND WITH THE UNDERSTANDING THAT IT IS NOT TO BE REPRODUCED, COPIED OR USED DIRECTLY OR INDIRECTLY, IN ANY WAY DETRIMENTAL TO OUR INTERESTS. ALL PATENT RIGHTS RESERVED.

REVISION		FILTER CONTROL LADDER DIAGRAM	
6-9-00		LINE #31	(6) REQ'D
8-3-00		FAYETTEVILLE, GA	L9-1477
3			
DRAWN BY	CHECKED BY	DATE	SCALE
TAZ		5-21-99	NONE
DWG NO		SH2	
1477.99.2		OF 9	



287 S. OAKSON STREET, ZELPHOPLE, PA 16823-1343

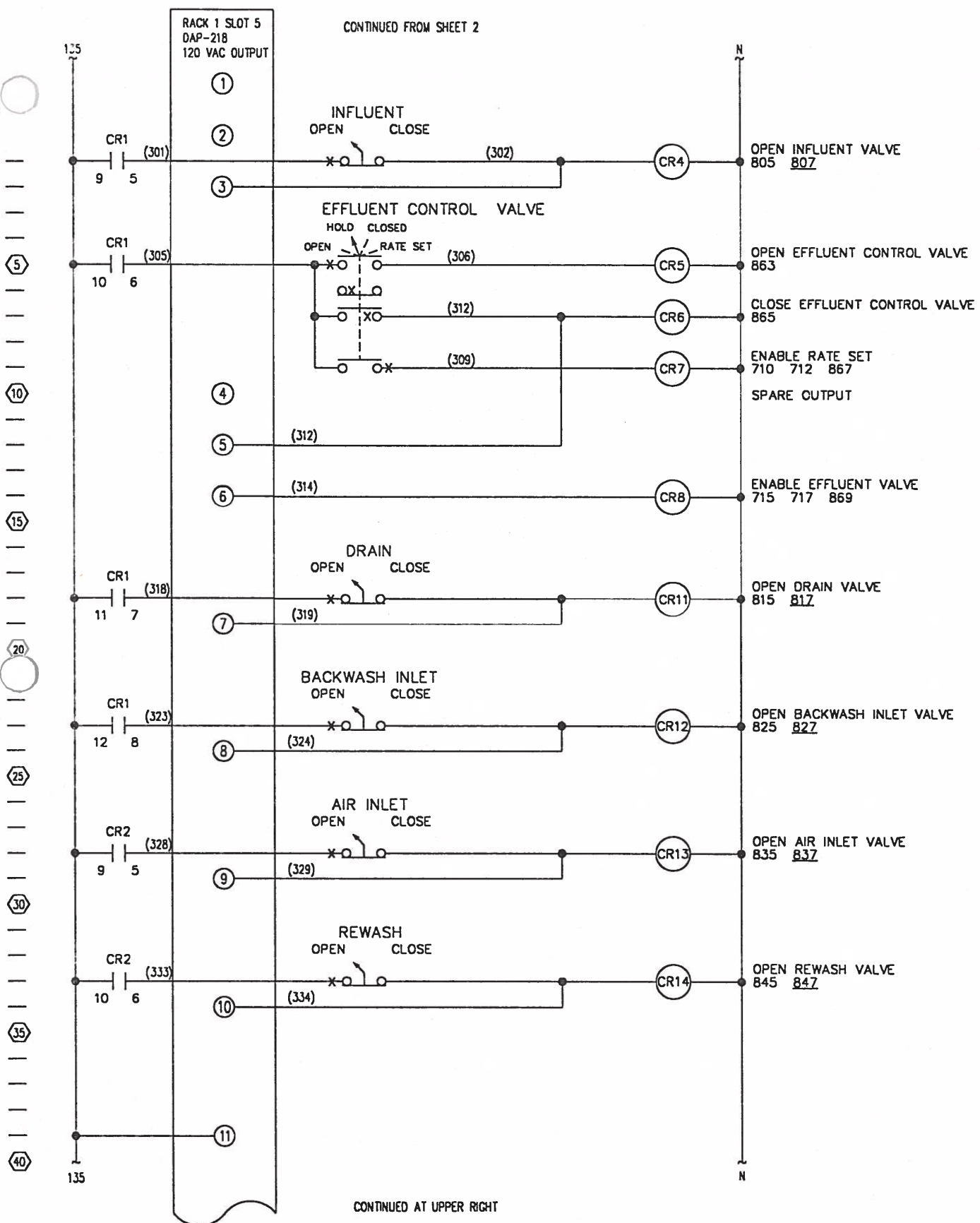

- 00001
- 00002
- 00003
- 00004
- 00005
- 00006
- 00007
- 00008

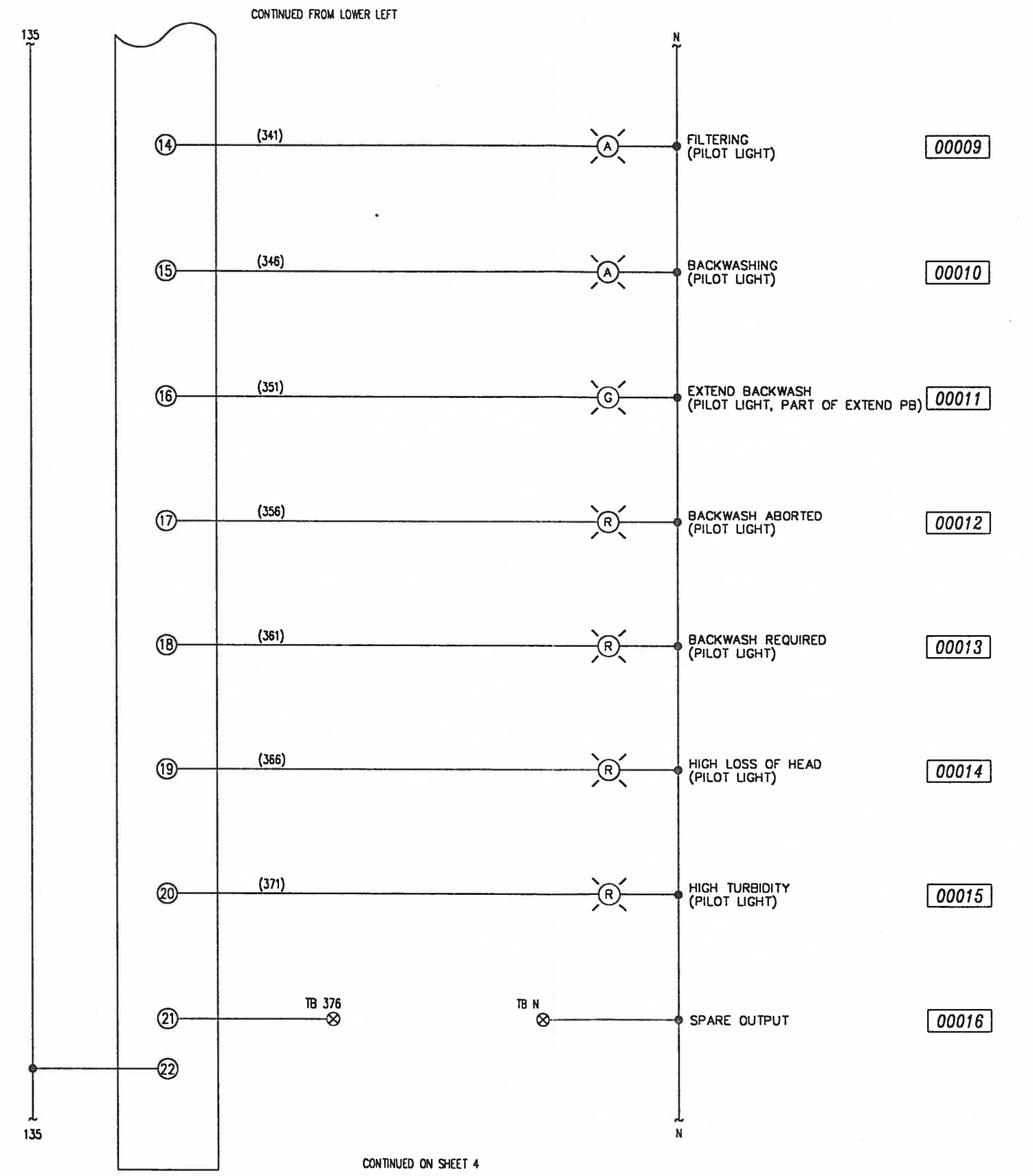

CONTINUED ON SHEET 4

NOTES:
1. SEE SHEET 1 FOR GENERAL NOTES
2. * INDICATES COMPONENTS NOT SUPPLIED BY LEOPOLD COMPANY

1. CORRECTED SELECTOR SWITCH WIRING, ADDED MISSING RELAY.

THIS DRAWING IS SENT TO YOU SUBJECT TO RETURN UPON DEMAND, AND WITH THE UNDERSTANDING THAT IT IS NOT TO BE REPRODUCED, COPIED OR USED DIRECTLY OR INDIRECTLY, IN ANY WAY DETRIMENTAL TO OUR INTERESTS. ALL PATENT RIGHTS RESERVED.

LEOPOLD
WATER & WASTEWATER PRODUCTS

REVISION		FILTER CONTROL LADDER DIAGRAM	
1	6-12-00	UNE #31	(6) REQ'D
2		FAYETTEVILLE, GA	L9-1477
3			
DRAWN BY	CHECKED BY	DATE	SCALE
TAZ		5-21-99	NONE
DWG NO	1477.99.2	SHJ	OF 9

227 S. DUNDON STREET, BELLEVILLE, PA 19003-1313

RACK 2 SLOT 1
DAP-218
120 VAC OUTPUT

CONTINUED FROM SHEET 3

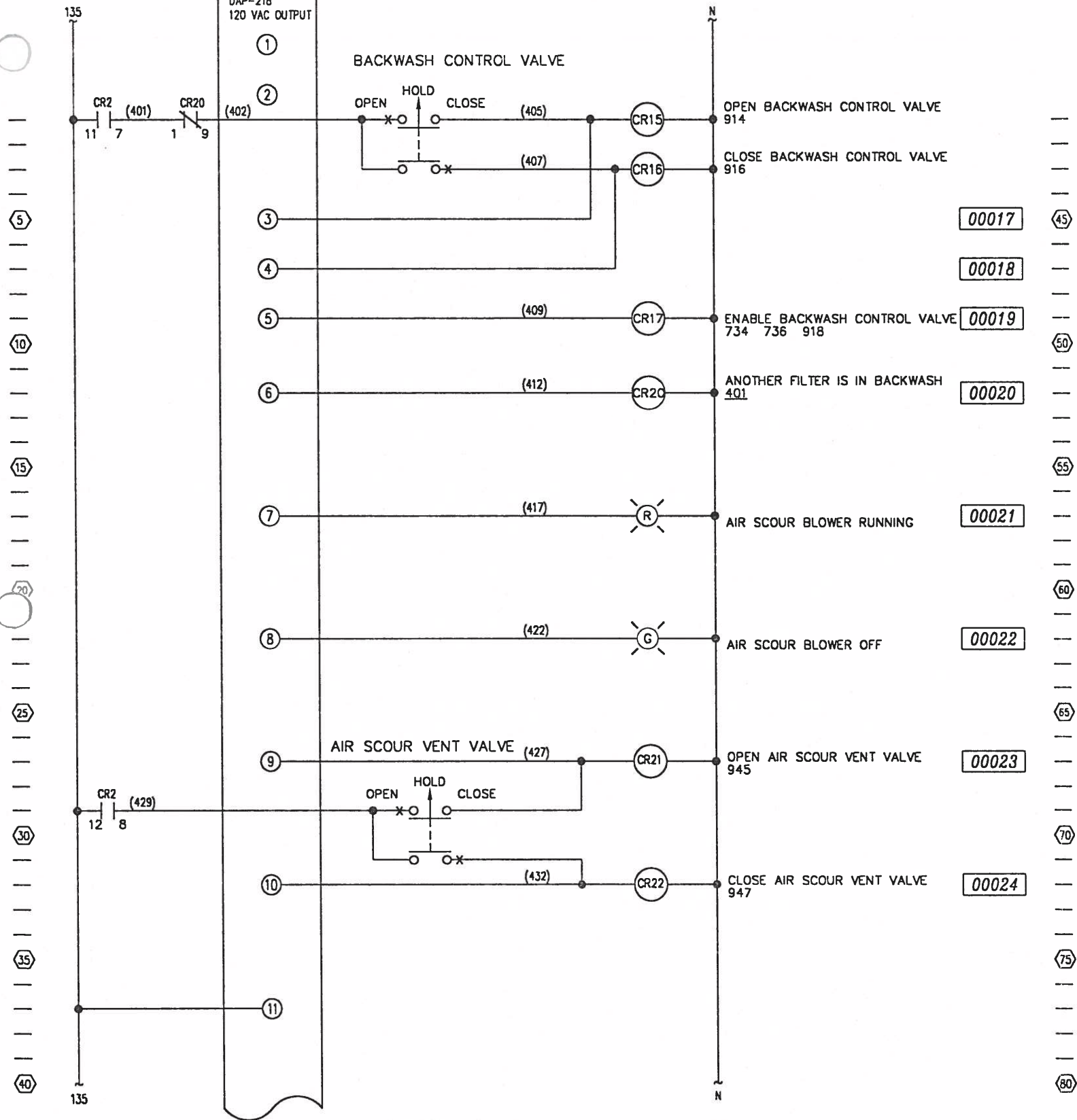

CONTINUED AT UPPER RIGHT

CONTINUED FROM LOWER LEFT

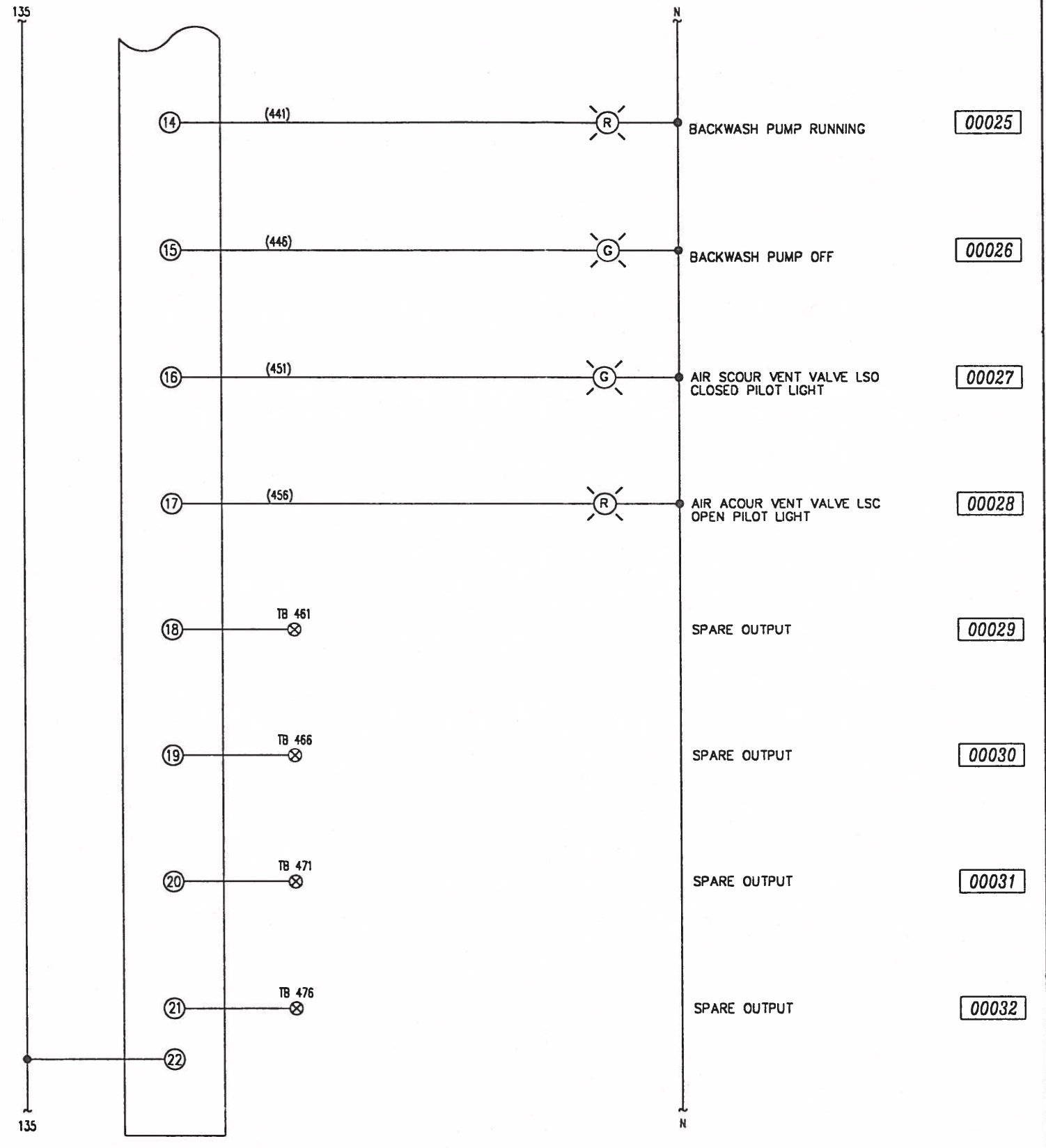

CONTINUED ON SHEET 8

- NOTES:
- SEE SHEET 1 FOR GENERAL NOTES
 - * INDICATES COMPONENTS NOT SUPPLIED BY LEOPOLD COMPANY

- REMOVE AIR VENT L.S. PILOT LIGHTS, THEY ARE ON SHEET #2.
- ADDED AIR SCOUR VENT VALVE HARDWIRED CONTROL. CHANGED FROM CONTROL OVER THE NETWORK.

<small>THIS DRAWING IS SENT TO YOU SUBJECT TO RETURN UPON DEMAND, AND WITH THE UNDERSTANDING THAT IT IS NOT TO BE REPRODUCED, COPIED OR USED DIRECTLY OR INDIRECTLY, IN ANY MANNER DEVIATING FROM OUR INTERESTS. ALL PATENT RIGHTS RESERVED.</small>		LEOPOLD WATER & WASTEWATER PRODUCTS	
REVISION 6-12-00 8-3-00	FILTER CONTROL LADDER DIAGRAM LINE #31 FAYETTEVILLE, GA	(6) REQ'D LS-1477	<small>227 S. GRAYSON STREET ZELDENOPLE, PA 16803-1303</small>
DRAWN BY TAZ	CHECKED BY	DATE 5-21-99	SCALE NONE
DWG NO 1477.99.2		SL# 9	OF 9

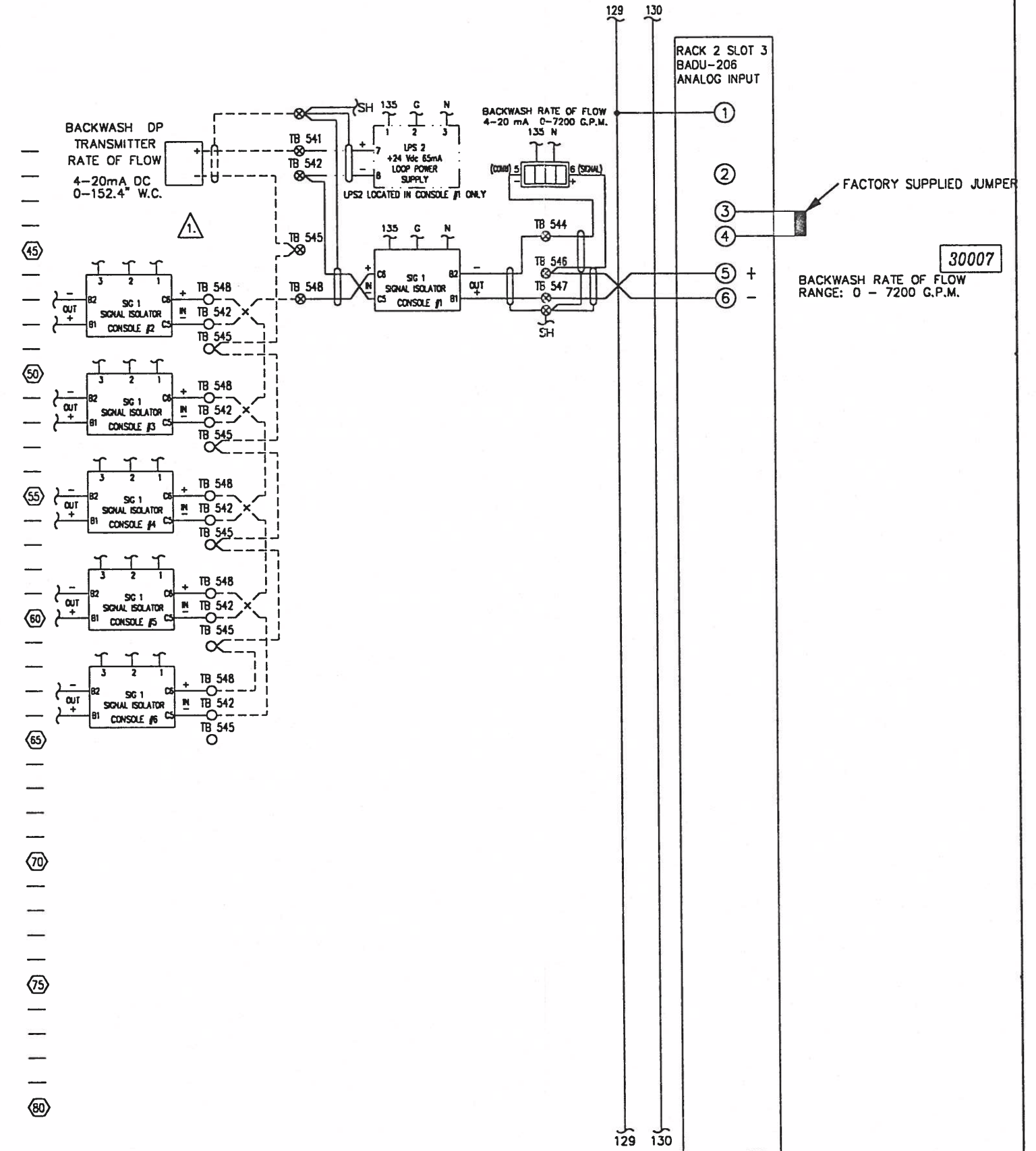
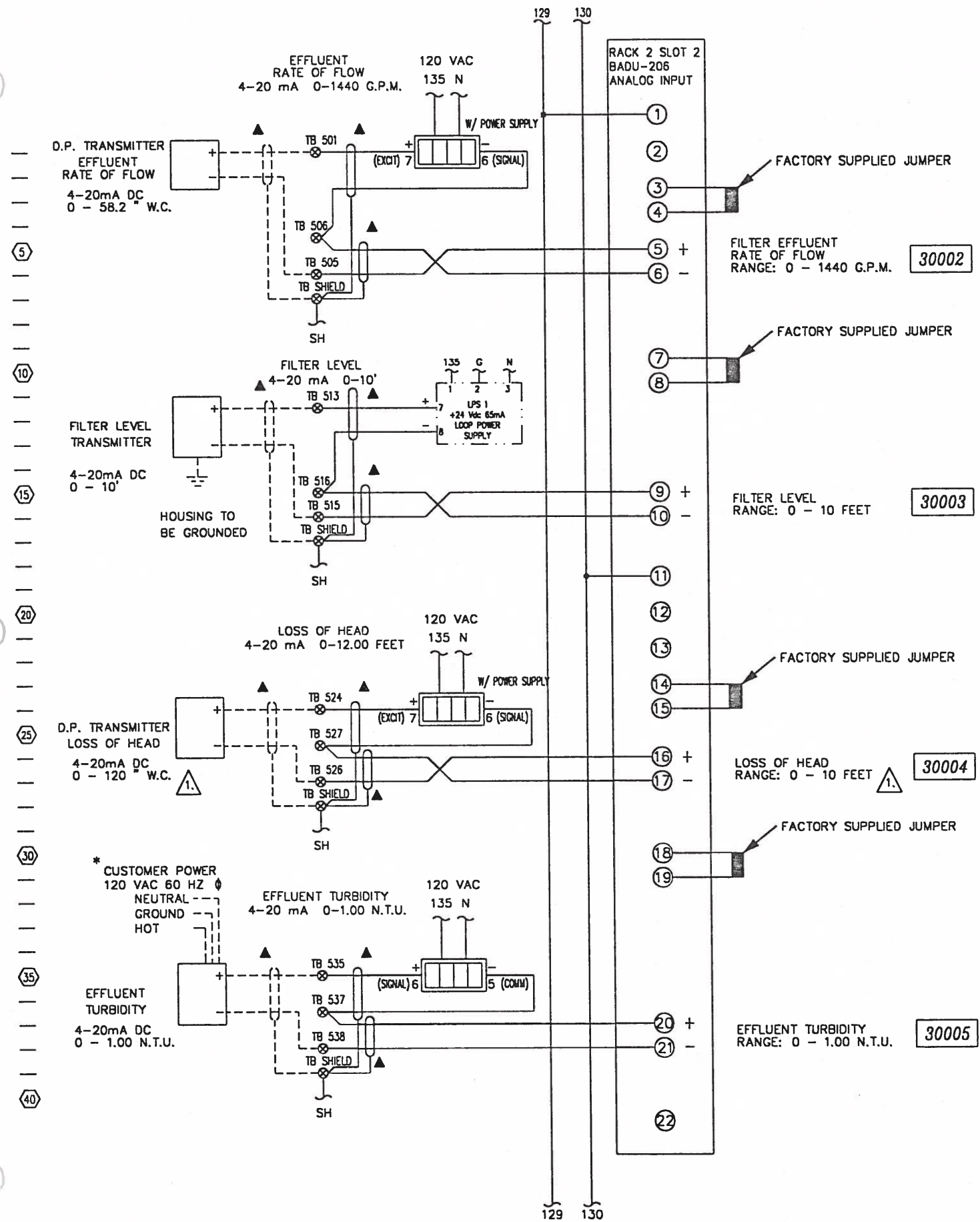

CONTINUED ON SHEET 6

- NOTES:
 1. SEE SHEET 1 FOR GENERAL NOTES
 2. * INDICATES COMPONENTS NOT SUPPLIED BY LEOPOLD COMPANY

⚠ CHANGED CAL. DATA OF LOH, CORRECTED PLC ADDRESSES, CORRECTED IN/OUT OF SIGNAL ISOLATORS. JSR

THIS DRAWING IS SENT TO YOU SUBJECT TO RETURN UPON DEMAND, AND WITH THE UNDERSTANDING THAT IT IS NOT TO BE REPRODUCED, COPIED OR USED DIRECTLY OR INDIRECTLY, IN ANY MANNER DETRIMENTAL TO OUR INTERESTS. ALL PATENT RIGHTS RESERVED.		LEOPOLD WATER & WASTEWATER PRODUCTS	
REVISION 1 5-31-00 2 3	FILTER CONTROL LADDER DIAGRAM LINE #31 FAYETTEVILLE, GA		(6) REQ'D L9-1477
DRAWN BY TAZ	CHECKED BY	DATE 5-21-99	SCALE NONE
DWG NO 1477.99.2		SHLS OF 9	

277 S. DIVISION STREET, ZELLENFELDE, PA 16803-1313

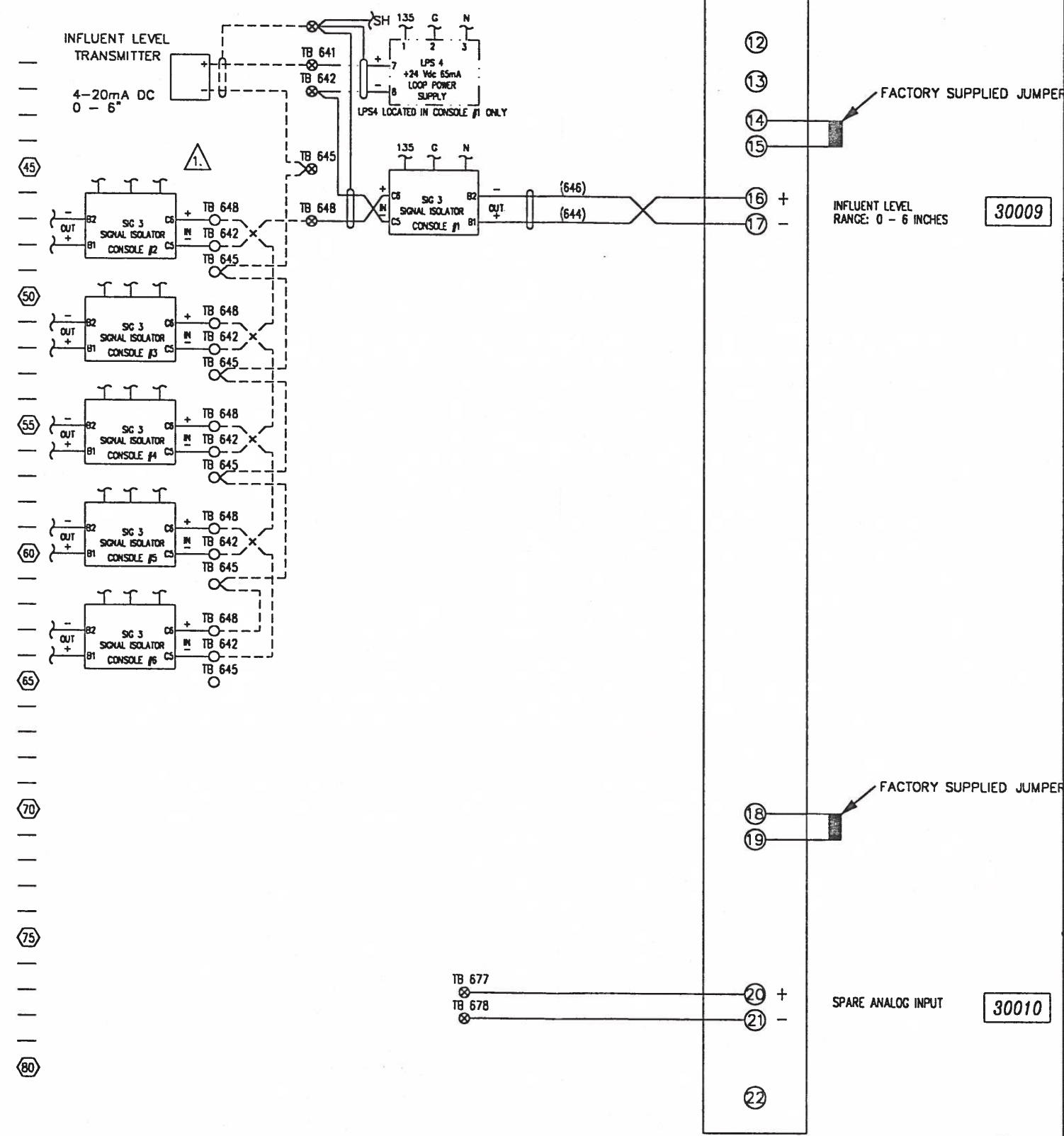
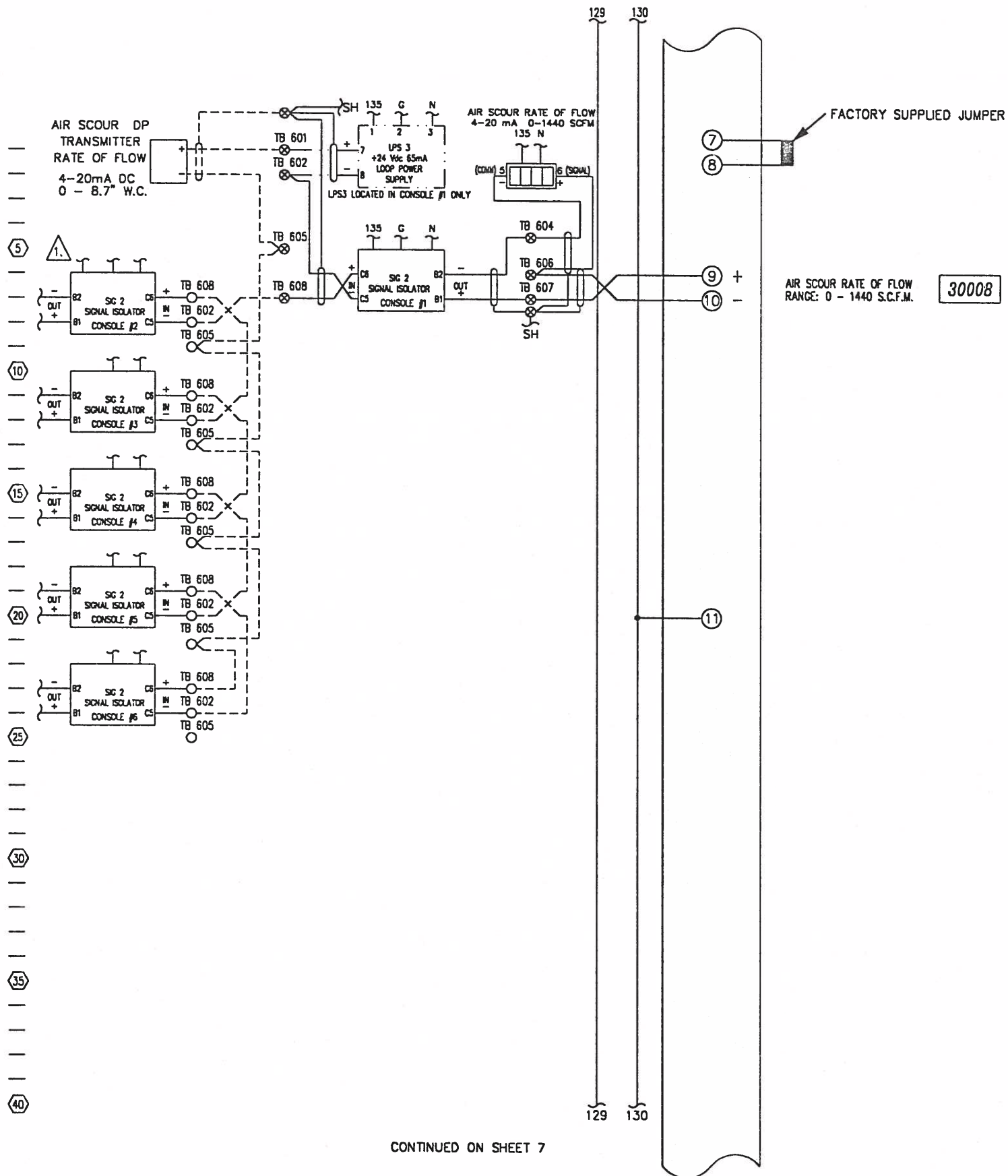

CONTINUED ON SHEET 7

NOTES:
 1. SEE SHEET 1 FOR GENERAL NOTES
 2. * INDICATES COMPONENTS NOT SUPPLIED BY LEOPOLD COMPANY

1. CORRECTED IN/OUT OF SIGNAL ISOLATORS, PLC ADDRESSES. JSR

<small>THIS DRAWING IS SENT TO YOU SUBJECT TO RETURN UPON DEMAND, AND WITH THE UNDERSTANDING THAT IT IS NOT TO BE REPRODUCED, COPIED OR USED DIRECTLY OR INDIRECTLY IN ANY WAY DETRIMENTAL TO OUR INTERESTS. ALL PATENT RIGHTS RESERVED.</small>			
REVISION 1 5-31-00 2 3	FILTER CONTROL LADDER DIAGRAM LINE #31 FAYETTEVILLE, GA	(6) REQ'D L9-1477	227 S. GIBSON STREET BLENHEIM, PA 15063-1313
DRAWN BY TAZ	CHECKED BY DATE 5-21-99	SCALE NONE	DWG NO 1477.99.2 SHL6 OF 9

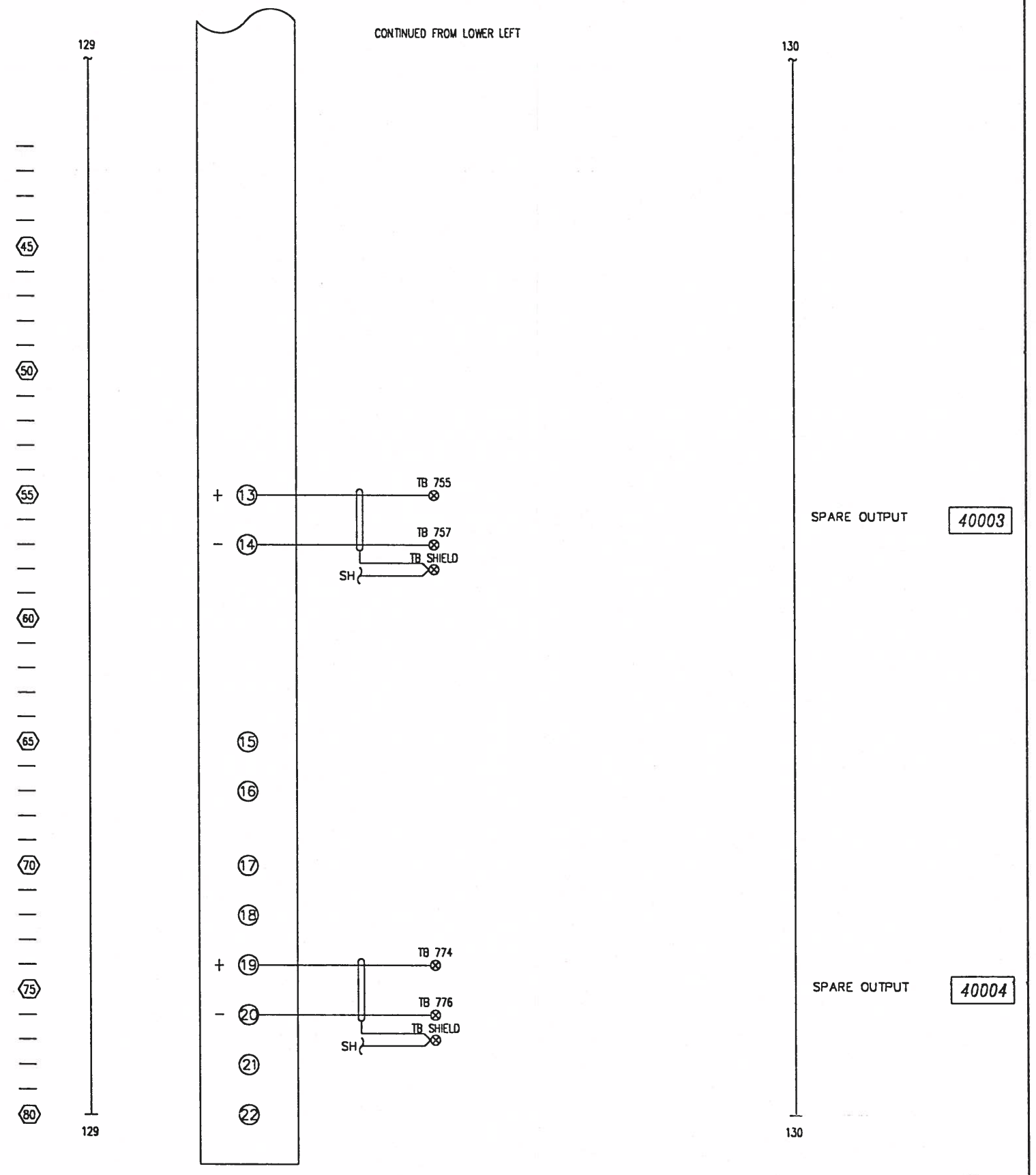
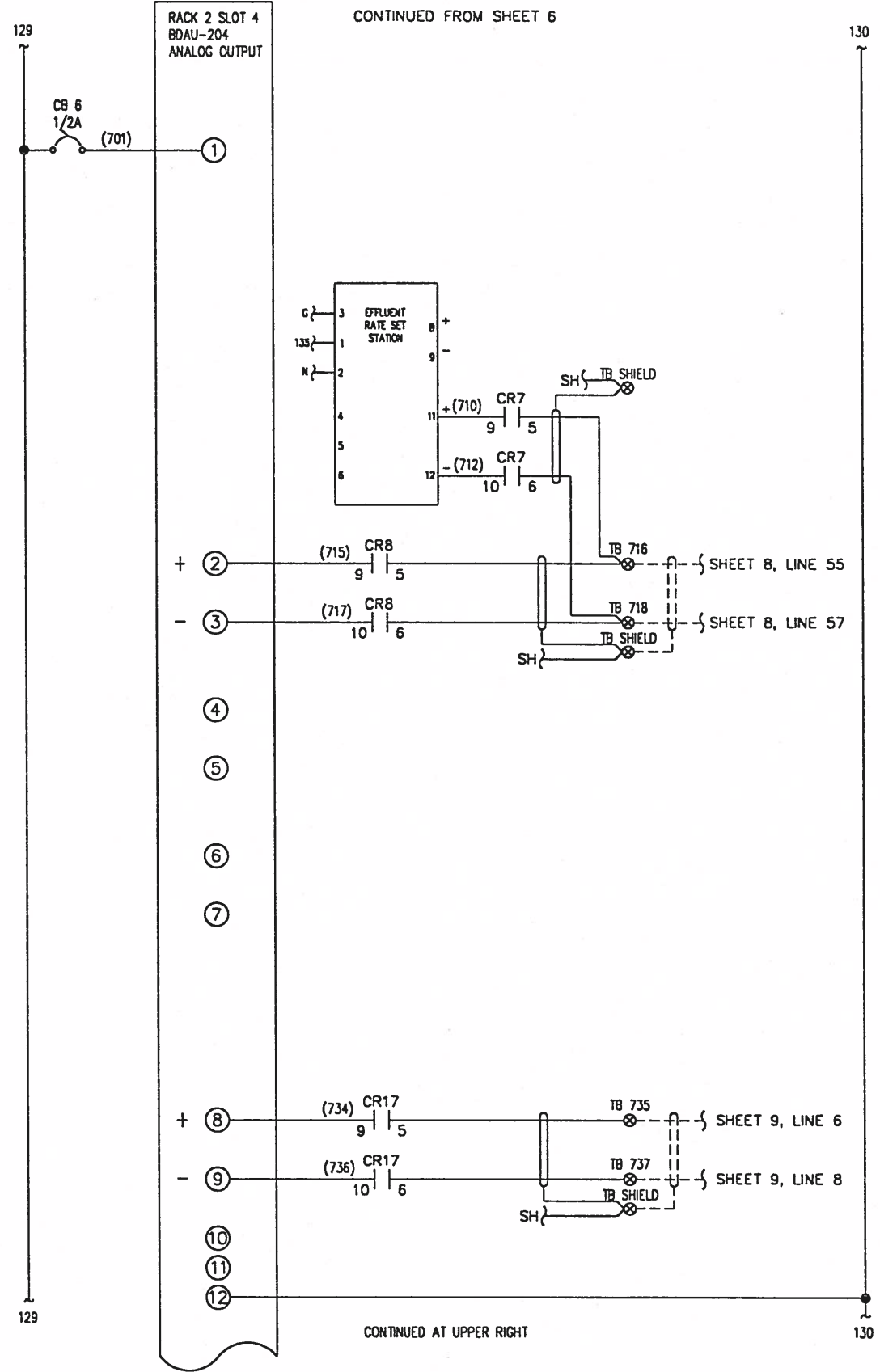

NOTES:
1. SEE SHEET 1 FOR GENERAL NOTES
2. * INDICATES COMPONENTS NOT SUPPLIED BY LEOPOLD COMPANY

THIS DRAWING IS SENT TO YOU SUBJECT TO RETURN UPON DEMAND, AND WITH THE UNDERSTANDING THAT IT IS NOT TO BE REPRODUCED, COPIED OR USED DIRECTLY OR INDIRECTLY, IN ANY WAY DETRIMENTAL TO OUR INTERESTS. ALL PATENT RIGHTS RESERVED.

REVISION	FILTER CONTROL LADDER DIAGRAM		
1	LINE #31	(6) REQ'D	
2	FAYETTEVILLE, GA	LS-1477	
3			
DRAWN BY	CHECKED BY	DATE	SCALE
TAZ		5-21-99	NONE
DWG NO	1477.99.2	SL7	OF 9

227 S. DIVISION STREET, ELDON, MO. 64603-1213

5

10

15

20

25

30

35

40

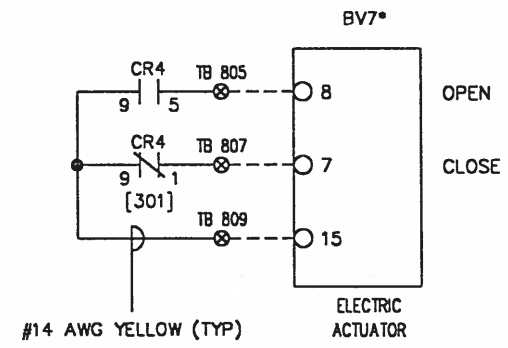

FILTER INFLUENT VALVE

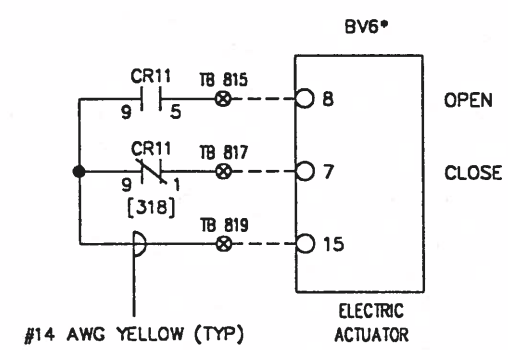

FILTER WASH DRAIN VALVE (DRAIN VALVE)

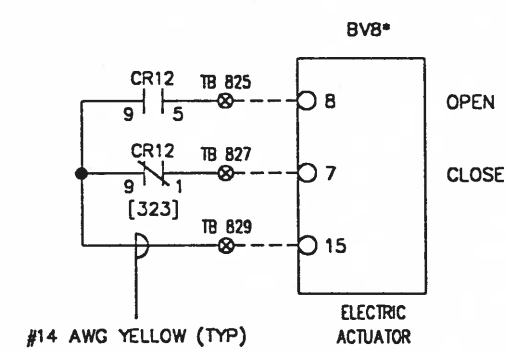

FILTER BACKWASH SUPPLY VALVE (BACKWASH VALVE)

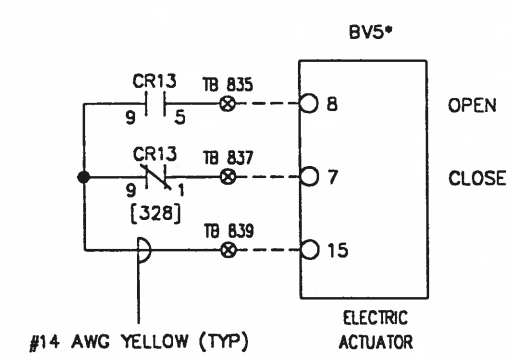

FILTER AIR WASH SUPPLY VALVE (AIR SCOUR INLET VALVE)

45

50

55

60

65

70

75

80

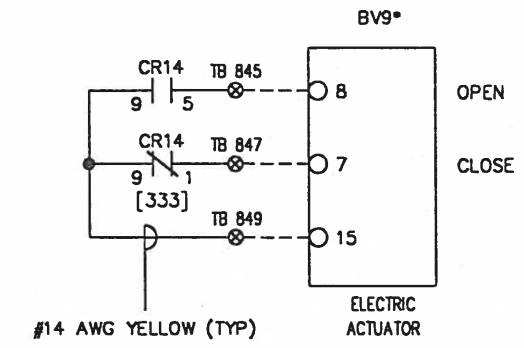

FILTER BACKWASH DRAIN VALVE (REWASH VALVE)

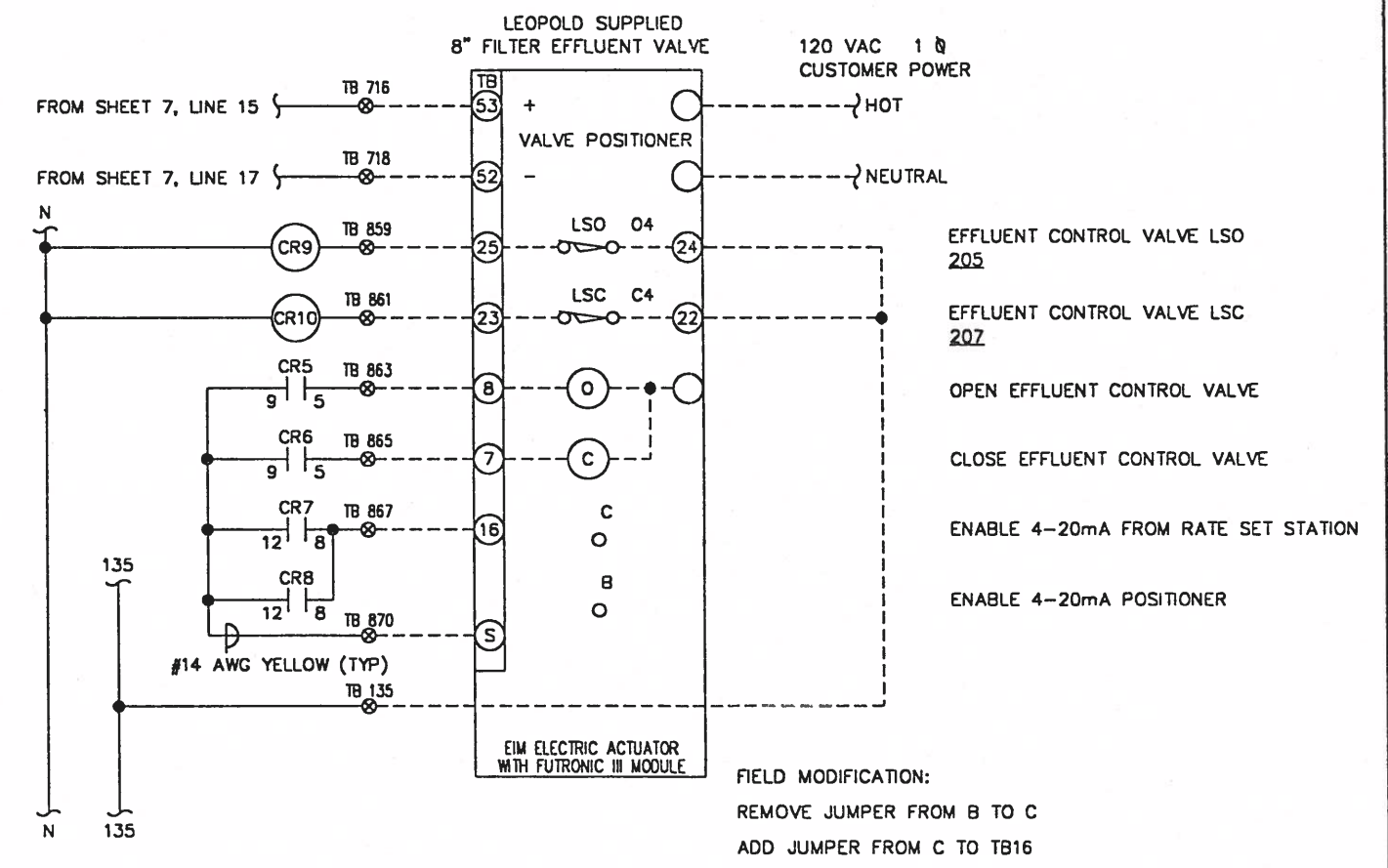

NOTES:
 1. SEE SHEET 1 FOR GENERAL NOTES
 2. * INDICATES COMPONENTS NOT SUPPLIED BY LEOPOLD COMPANY

REVISION		FILTER CONTROL LADDER DIAGRAM	
1	6-1-00	LINE #31	(6) REQ'D
2		FAYETTEVILLE, GA	LS9-1477
3			
DRAWN BY	CHECKED BY	DATE	SCALE
TAZ		5-21-99	NONE
DWG NO	1477.99.2	SH.B	OF 8

LEOPOLD
 WATER & WASTEWATER PRODUCTS
227 S. GIBSON STREET, LEOPOLD, PA 16093-1313

LEOPOLD SUPPLIED
16" BACKWASH CONTROL VALVE

120 VAC 1 Ø
CUSTOMER POWER

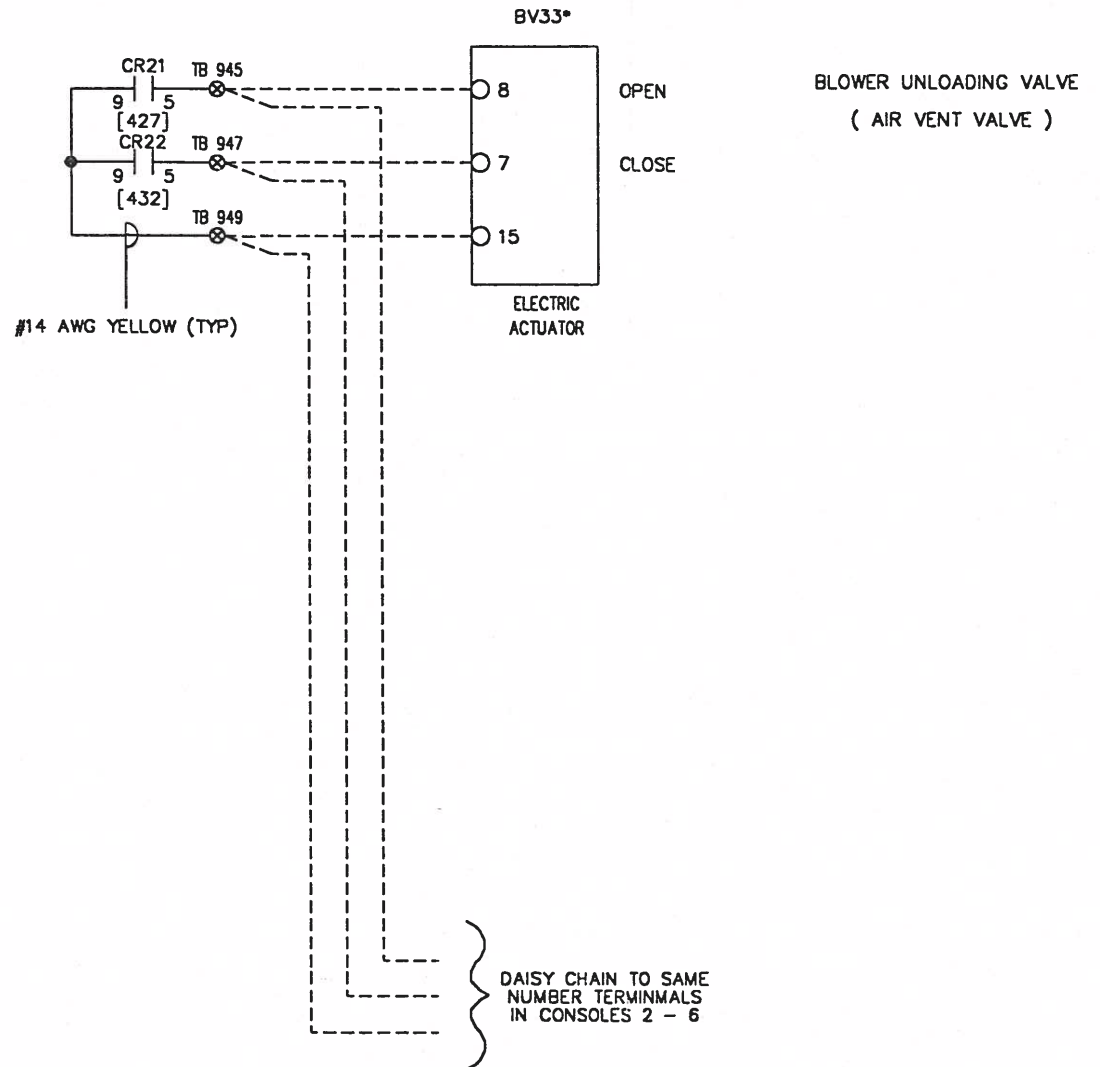
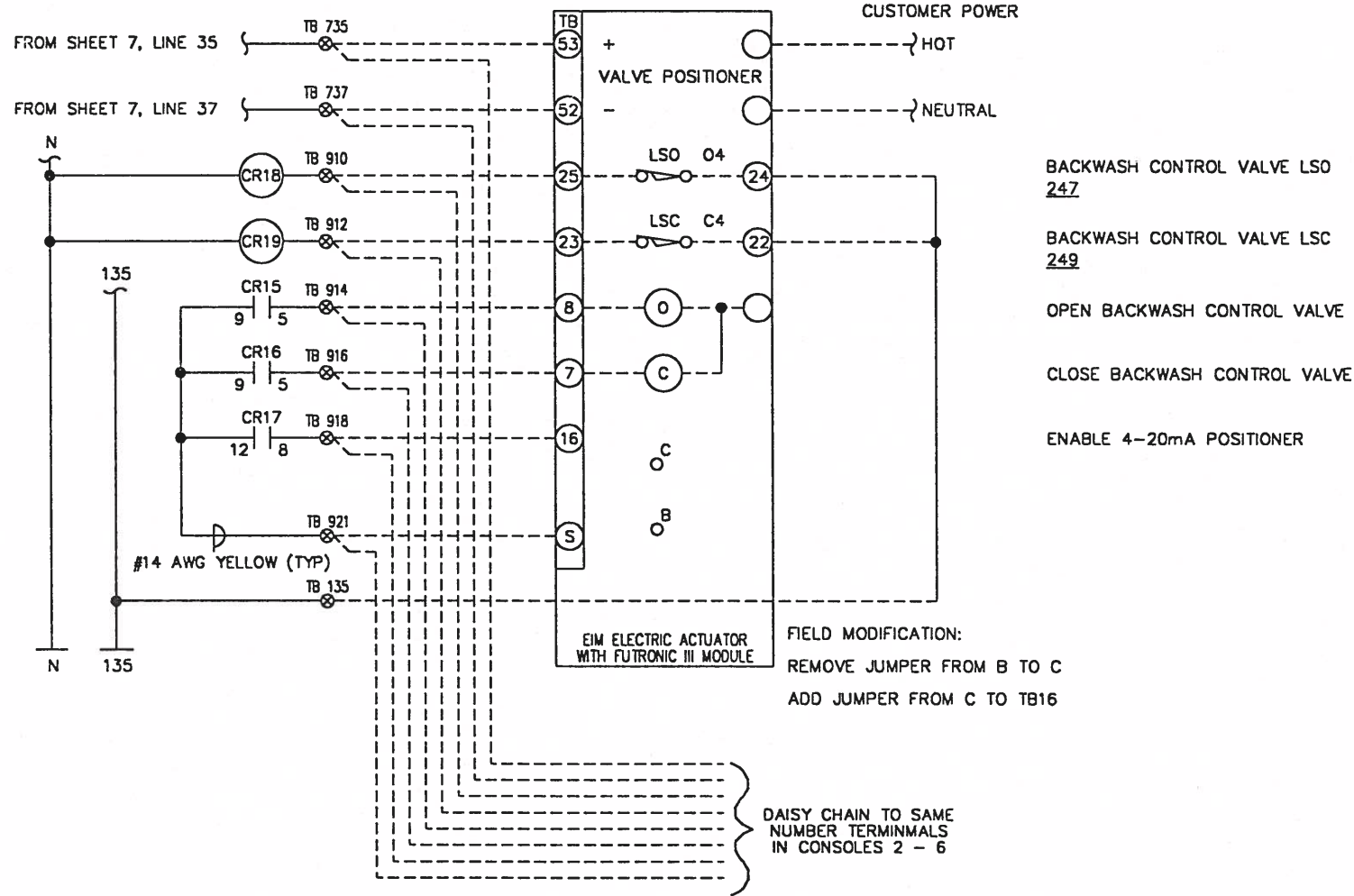

NOTES:

1. SEE SHEET 1 FOR GENERAL NOTES
2. * INDICATES COMPONENTS NOT SUPPLIED BY LEOPOLD COMPANY

<small>THIS DRAWING IS SENT TO YOU SUBJECT TO RETURN UPON DEMAND, AND WITH THE UNDERSTANDING THAT IT IS NOT TO BE REPRODUCED, COPIED OR USED DIRECTLY OR INDIRECTLY, IN ANY WAY DETRIMENTAL TO OUR INTERESTS. ALL PATENT RIGHTS RESERVED.</small>			
REVISION	6-2-00	FILTER CONTROL LADDER DIAGRAM	
2	8-3-00	LINE #31	(6) REQ'D
3		FAYETTEVILLE, GA	L9-1477
DRAWN BY	CHECKED BY	DATE	SCALE
TAZ		5-21-99	NONE
DWG NO	1477.99.2	REV	9
			OF 9

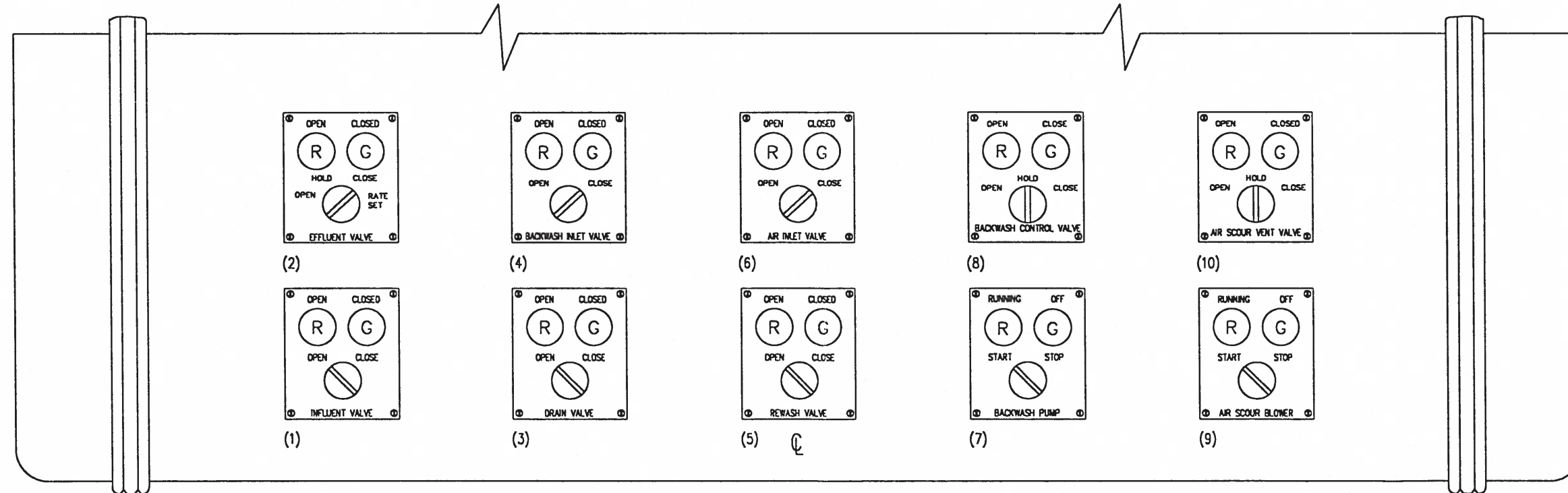
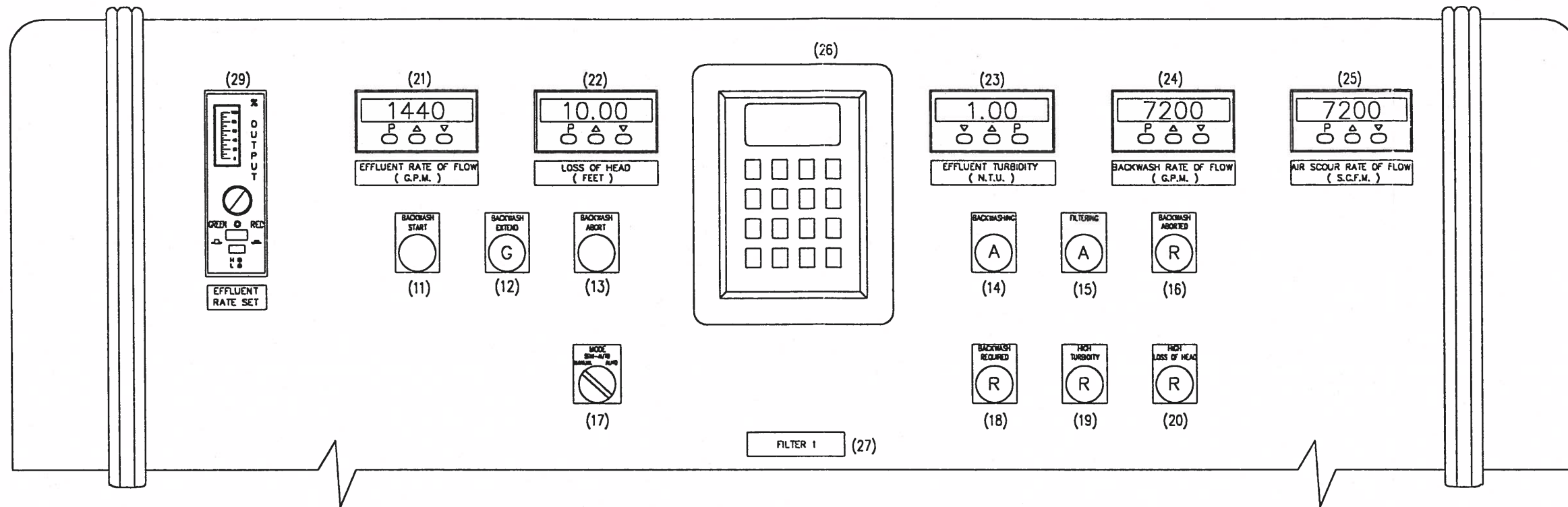

THIS DRAWING IS SENT TO YOU SUBJECT TO RETURN UPON DEMAND, AND WITH THE UNDERSTANDING THAT IT IS NOT TO BE REPRODUCED, COPIED OR USED DIRECTLY OR INDIRECTLY, IN ANY WAY OR MANNER, TO OUR PREJUDICE. ALL PATENT RIGHTS RESERVED.

REVISION		FILTER CONTROL CONSOLE DETAIL VIEW		
1		LINE "31"	(6) REQ'D	
2		FAYETTEVILLE, GA	LS-1477	
3				227 S. SPANISH STREET, BELLEVILLE, PA. 19003-1313
DRAWN BY	CHECKED BY	DATE	SCALE	DWG NO
TAZ		5-21-99	AS NOTED	1477.99.3

VIEW - "A"
(SCALE: 1/4" = 1")

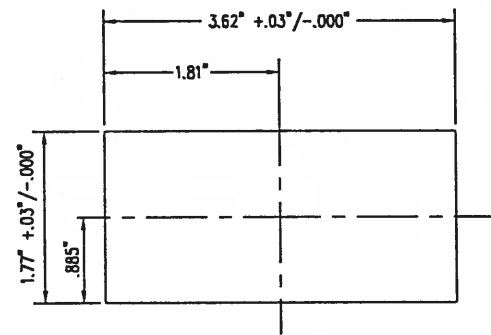
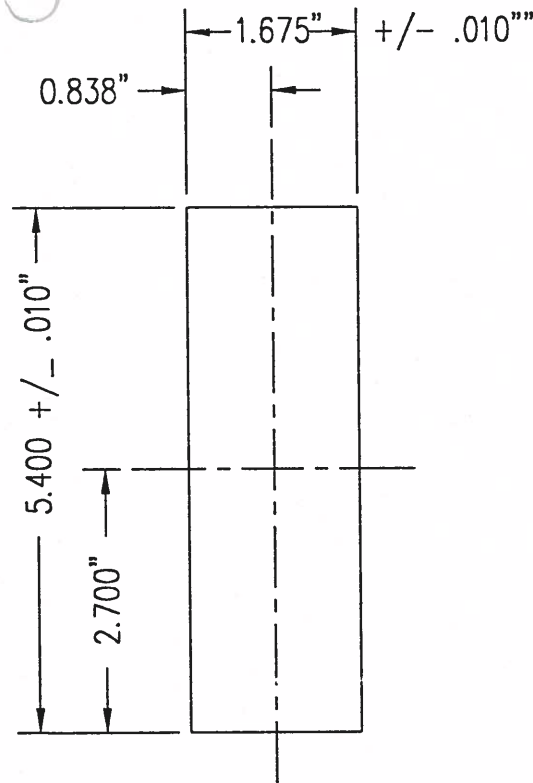
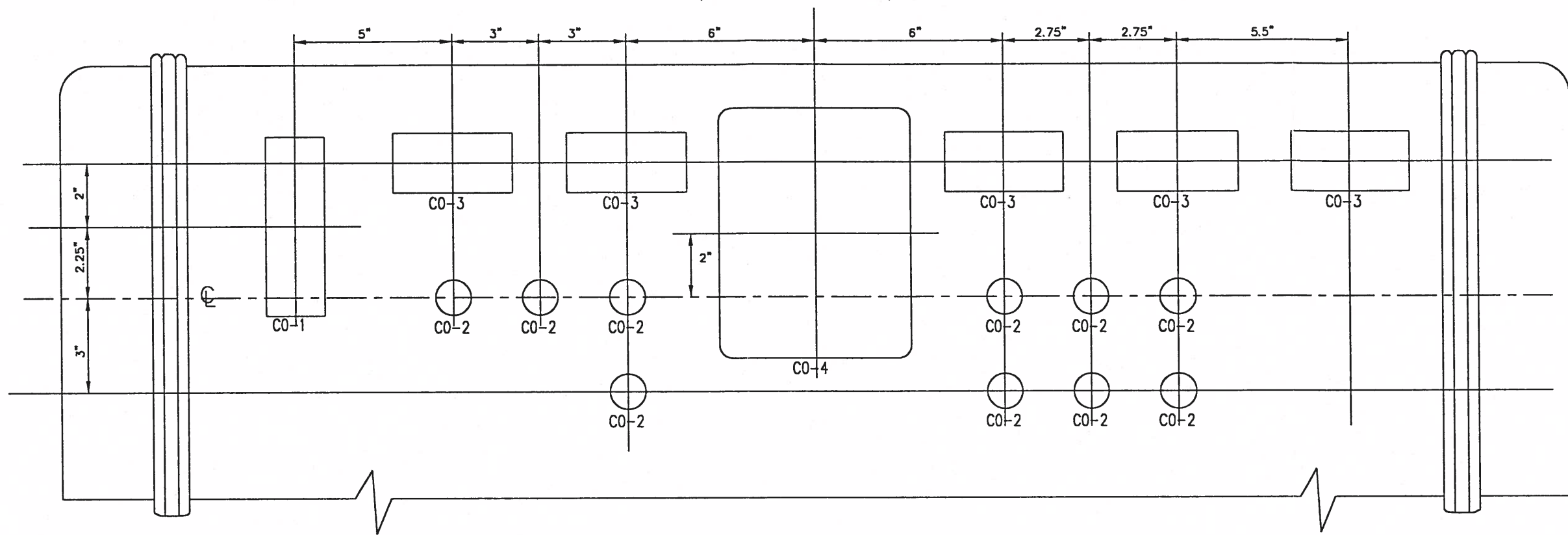

RED LION MODEL IMP APOLLO DIGITAL INDICATOR CO-3 (5) REQ'D

DRILL (4) CLEARANCE HOLES FOR #8 SCREW

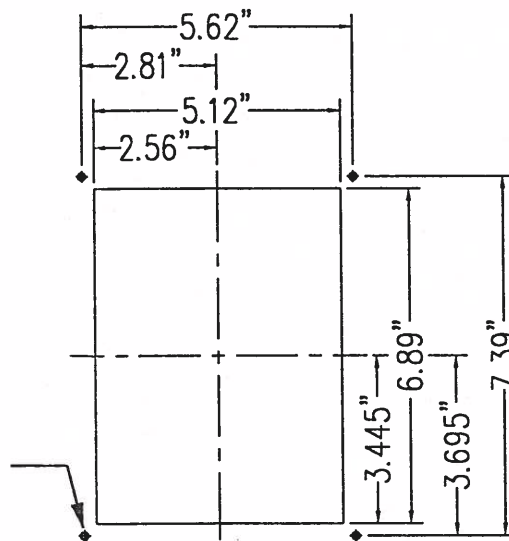

MT200 OPERATOR INTERFACE TERMINAL CO-4 1 - REQ'D SCALE: 1/2" = 1"

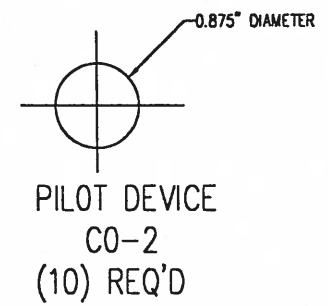

RATE SET STATION CO-1 1 - REQ'D SCALE: FULL

- NOTES:
- ALL DIMENSIONS IN INCHES
 - MAT'L FOR MOUNTING PLATE TO BE 3/16" THICK FRP RESIN
 - COLOR: MATCH INMEC DELFT BLUE G803

THIS DRAWING IS SENT TO YOU SUBJECT TO RETURN UPON DEMAND, AND WITH THE UNDERSTANDING THAT IT IS NOT TO BE REPRODUCED, COPIED OR USED DIRECTLY OR INDIRECTLY, IN ANY WAY DETRIMENTAL TO OUR INTERESTS. ALL PATENT RIGHTS RESERVED.		FRP TOP FRONT MOUNTING PLATE CUTOUTS	
REVISION	LINE #31	(6) REQ'D	
1			
2			
3	FAYETTEVILLE, GA	L9-1477	
DRAWN BY	CHECKED BY	DATE	SCALE
TAZ		5-21-99	AS NOTED
DWG NO	1477.99.4	SL1	OF 2



287 S. GIVISON STREET, ZELIENOPLE, PA 15083-1393

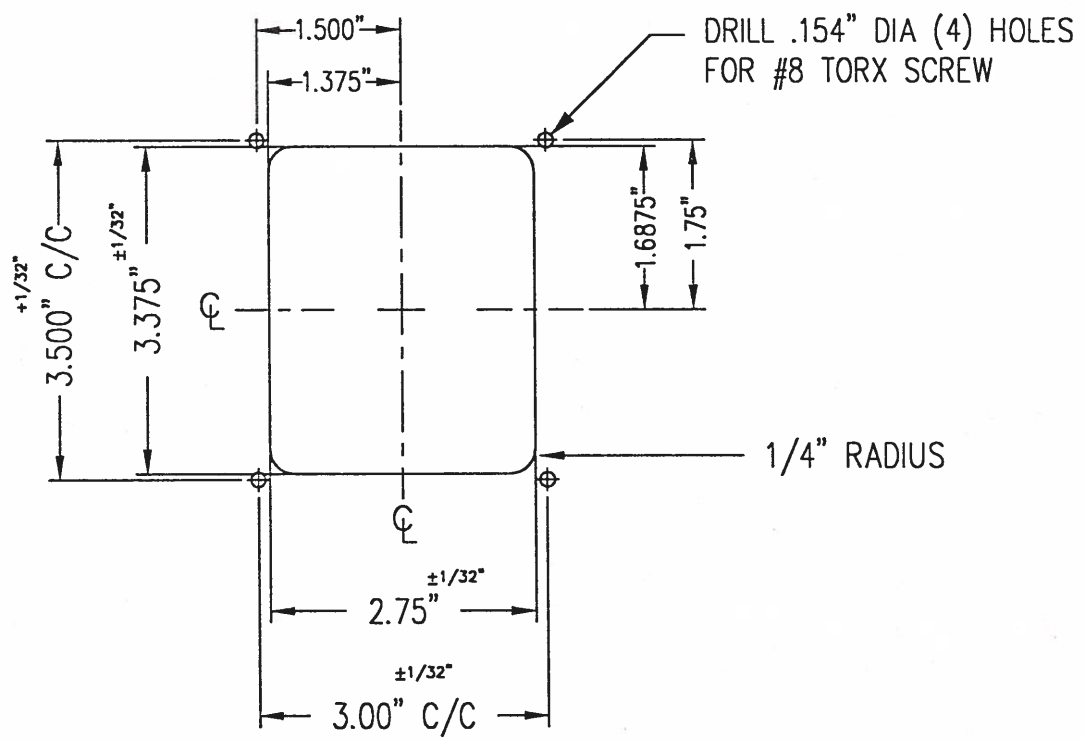
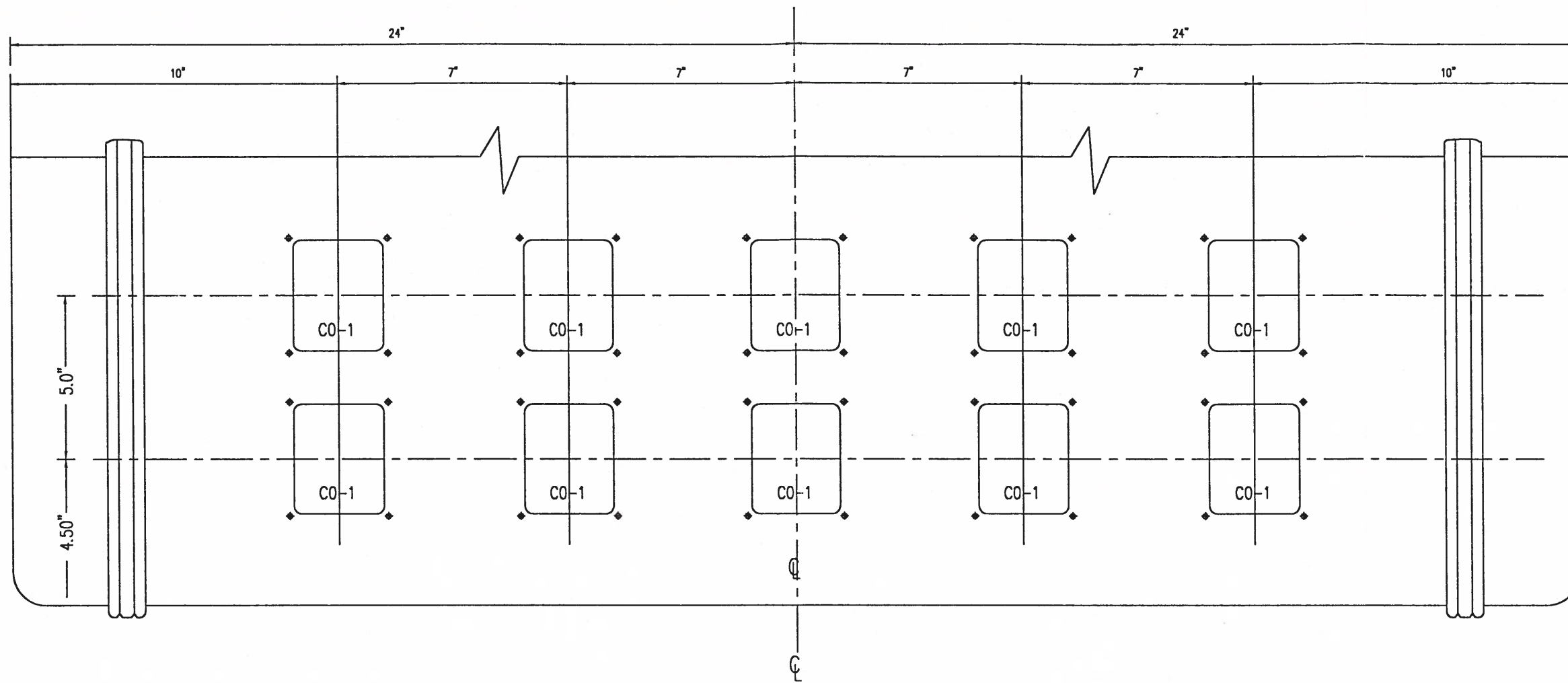

CONTROL STATION
CO-1
10 - REQ'D
SCALE = FULL

THIS DRAWING IS SENT TO YOU SUBJECT TO RETURN UPON DEMAND, AND WITH THE UNDERSTANDING THAT IT IS NOT TO BE REPRODUCED, COPIED OR USED DIRECTLY OR INDIRECTLY, IN ANY WAY RETRIBUTIVE, TO OUR INTERESTS. ALL PATENT RIGHTS RESERVED.

REVISION	FRP BOTTOM FRONT MOUNTING PLATE CUTOUTS
1	
2	LINE #31 (6) REQ'D
3	FAYETTEVILLE, GA L9-1477

DRAWN BY	CHECKED BY	DATE	SCALE	DWG NO	SH2
TAZ		5-21-99	AS NOTED	1477.99.4	OF 2



227 S. DIVISION STREET, BELLEVILLE, PA 19008-1213

DISCRETE SIGNALS (TB1)

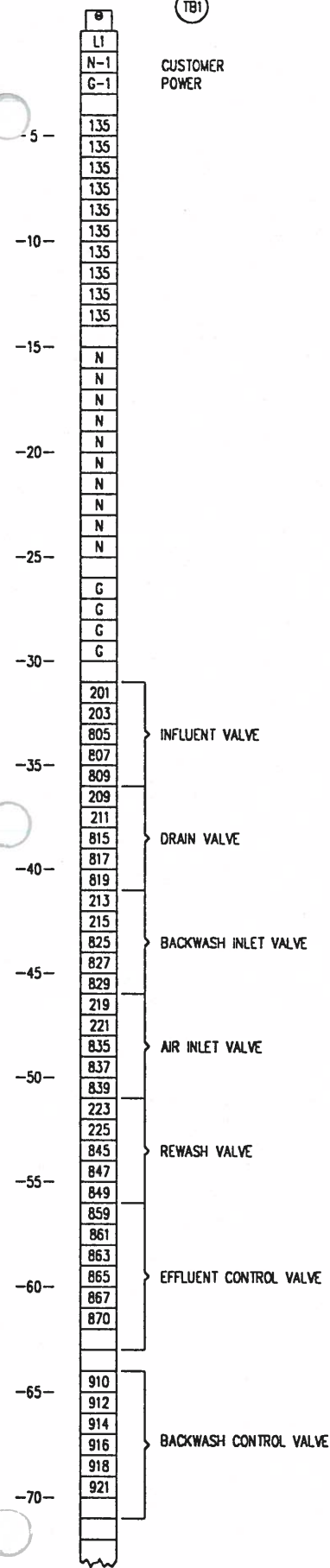

CONTINUED AT UPPER RIGHT

CONTINUED FROM LOWER LEFT

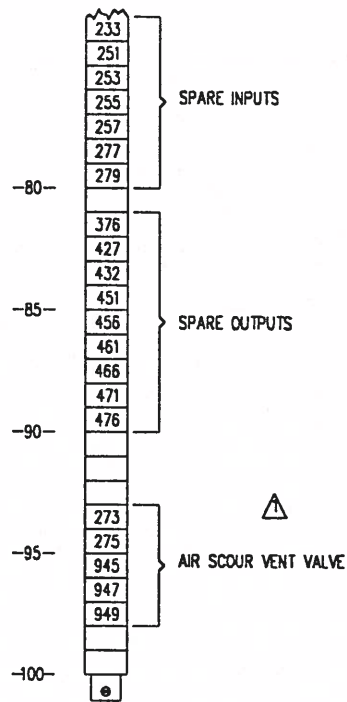

ANALOG SIGNALS (TB2)

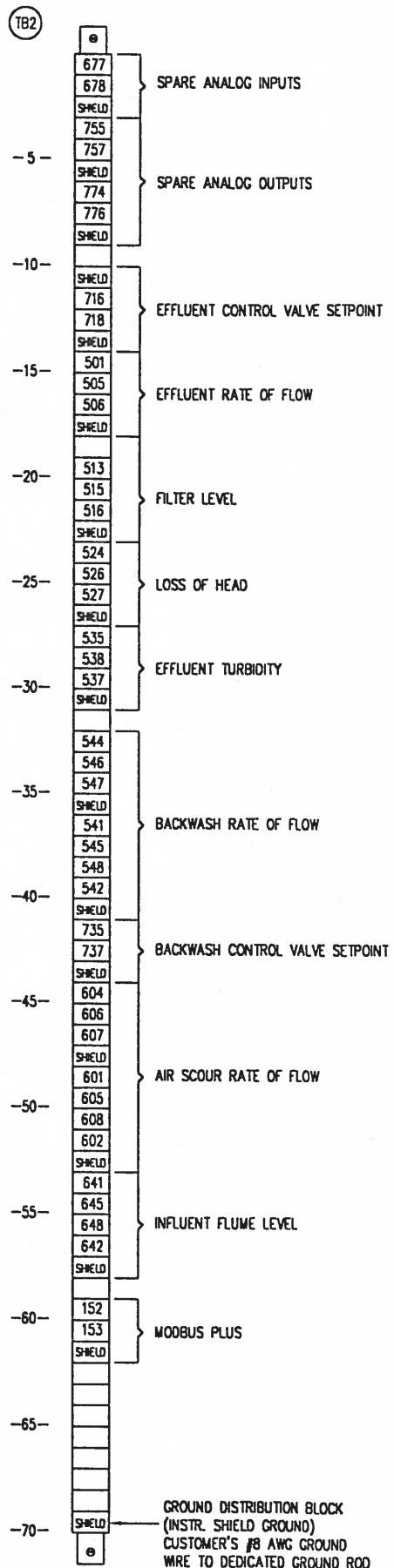

GROUND DISTRIBUTION BLOCK (INSTR. SHIELD GROUND) CUSTOMER'S #8 AWG GROUND WIRE TO DEDICATED GROUND ROD

FOR FILTER CONTROL CONSOLE ARRANGEMENT SEE DWG #1477.99.1
FOR FILTER CONTROL LADDER DIAGRAM SEE DWG #1477.99.2

NOTE:
* = COMPONENTS NOT SUPPLIED BY LEOPOLD COMPANY

<small>THIS DRAWING IS SENT TO YOU SUBJECT TO RETURN UPON DEMAND, AND WITH THE UNDERSTANDING THAT IT IS NOT TO BE REPRODUCED, COPIED OR USED DIRECTLY OR INDIRECTLY, IN ANY WAY DETRIMENTAL TO OUR INTERESTS. ALL PATENT RIGHTS RESERVED.</small>		
REVISION 1 6-13-00 2 3	FCP TERMINAL BLOCK LAYOUT FILTER CONSOLE LINE #31 (6) REQ'D FAYETTEVILLE, GA L9-1477	
DRAWN BY TAZ	CHECKED BY DATE 5-21-99	SCALE NONE
DWG NO 1477.99.6		<small>217 S. DUNSMUIR STREET, ELLICOTTVILLE, PA 16653-1343</small>

BILL OF MATERIAL

PROJECT NAME :

FAYETTEVILLE, GA

BM NO: 1477.69.1 MANFACT L9-1477-PAN-1
LINE #31 - 48" FILTER CONTROL CONSOLE
CONTRACT NO: L9-1477
RELEASE DATE: 14 JUNE 2000

PREPARED BY: TAZ
APPROVED BY:

ITEM QUANTITY 6

MK NO.	DESCRIPTION	PER QTY	TOT QTY	PART NUMBER	VENDOR	P.O. #	UNIT COST	EXTD COST
1	CONSOLE, FRP TYPE, 48x50x24, COLOR-MATCH TNEMEC DELFT BLUE, INCLUDES, FRONT & REAR CENTER PANELS, RIGHT & LEFT END PANELS,	1	6	L9-1477-CONSOLE/DOOR				
2	ALUMINUM HINGED REAR MOUNTING PLATE, TOP SECTION, 1/4"	1	6	108-103-280				
3	ALUMINUM HINGED REAR MOUNTING PLATE, BOTTOM SECTION, 1/4"	1	6	108-103-281				
4	ALUMINUM SUBPANEL, 1/4" X 39 3/4" X 36"	1	6	108-103-291				
5	ROUND HEAD MACHINE SCREWS, S.S., #10 - 24 X 3/4, W/NUTSERTS	14	84	105-103-031				
6	CONTINUOUS HINGE, 72 X 2 X .060, McMASTER CARR P/N 1658A847 (TRIM TO SUIT)	1	6	107-005-110				
7	TERMINAL BLOCK, SQUARE D 9080-M4/6	170	1020	110-005-151				
8	END SECTION, TERMINAL BLOCK, SQUARE D 9080-MFEM6	5	30	110-005-152				
9	END CLAMP, TERMINAL BLOCK, SQUARE D 9080-MH10	10	60	110-005-153				
10	MARKER, TERMINAL BLOCK, SQUARE D 9080-MH21	340	2040	110-005-154				
11	TERMINAL JUMPER BAR, 10 POLE FOR M4/6 TB'S, SQUARE D MH-70	7	42	110-005-155				
12	MOUNTING RAIL, SQUARE D 9080-MH379	7	42	110-005-150				
13	CIRCUIT BREAKER, 20 AMP, SQUARE D MG24509, CB1	1	6	110-017-048				
14	CIRCUIT BREAKER, 3 AMP, SQUARE D 9080-GCB30, CB2	1	6	110-017-045				
15	CIRCUIT BREAKER, 2 AMP, SQUARE D 9080-GCB20, CB3	1	6	110-017-103				
16	CIRCUIT BREAKER, 10 AMP, SQUARE D 9080-GCB100, CB4	1	6	110-017-109				
17	CIRCUIT BREAKER, 1 AMP, SQUARE D 9080-GCB10, CB5	1	6	110-017-101				
18	CIRCUIT BREAKER, 1/2 AMP, SQUARE D 9080-GCB05, CB6	1	6	110-017-100				
19	RELAY, 4 POLE, SQUARE D, CLASS 8501, RS44P14V20	6	36	110-027-070				
20	RELAY SOCKET, 4 POLE, SQUARE D, CLASS 8501, NR34	6	36	110-027-080				
21	RELAY, 2 POLE, SQUARE D, CLASS 8501, RS42P14V20	16	96	110-027-071				

BILL OF MATERIAL

PROJECT NAME :

FAYETTEVILLE, GA

BM NO: 1477.69.1 MANFACT L9-1477-PAN-1

PREPARED BY: TAZ

LINE #31 - 48" FILTER CONTROL CONSOLE

APPROVED BY:

CONTRACT NO: L9-1477

RELEASE DATE: 14 JUNE 2000

ITEM QUANTITY 6

MK NO.	DESCRIPTION	PER QTY	TOT QTY	PART NUMBER	VENDOR	P.O. #	UNIT COST	EXTD COST
22	RELAY SOCKET, 2 POLE, SQUARE D, CLASS 8501, NR42	16	96	110-027-081				
23	SELECTOR SWITCH, 2 POSITION MAINTAINED, SQUARE D P/N ZB2-BD2 (32)	7	42	110-018-020				
24	SELECTOR SWITCH, 4 POS.MAINT'D., CONTACT ASS'Y., SQUARE D P/N 9003K2D004NA	1	6	110-018-094				
25	KNOB - XB2B STYLE, SQUARE D P/N ZBCZ1M12	1	6	110-018-095				
26	SELECTOR SWITCH ADAPTER, SQUARE D P/N KZ127	1	6	110-018-096				
27	SELECTOR SWITCH, 3 POSITION MAINTAINED, SQUARE D P/N ZB2-BD3 (33, 31, 31)	1	6	110-018-022				
28	SELECTOR SWITCH, 3 POS.SPRING RET. TO CENTER, SQUARE D P/N ZB2-BD5 (33)	2	12	110-018-021				
29	PUSHBUTTON OPERATOR, FLUSH HEAD, GREEN, SQUARE D ZB2-BA3 (32)	1	6	110-011-025				
30	PUSHBUTTON OPERATOR, EXT. HEAD, RED, SQUARE D ZB2-BL4 (ABORT BW) (32)	1	6	110-011-026				
31	CONTACT BLOCK , 1 N.C., SQUARE D P/N ZB2-BE102	2	12	110-005-087				
32	CONTACT BLOCK W/BASE, 1 N.O., 1 N.C., SQUARE D P/N ZB2-BZ105	9	54	110-005-085				
33	CONTACT BLOCK W/BASE, 2 N.O., SQUARE D P/N ZB2-BZ103	3	18	110-050-022				
34	PUSHBUTTON OPERATOR, ILLUMINATED, GREEN, SQUARE D ZB2-BW33 (35)	1	6	110-011-041				
35	MNT'G BASE, TRANS. TYPE, 120V, W/1 N.O., 1N.C. CONT. BLOCK, SQUARE D, ZB2-BW035	1	6	110-050-029				
36	PILOT LIGHT, GREEN, SQUARE D P/N ZB2-BV03 (39)	10	60	110-019-035				
37	PILOT LIGHT, RED, SQUARE D P/N ZB2-BV04 (39)	14	84	110-019-036				
38	PILOT LIGHT, AMBER, SQUARE D P/N ZB2-BV05 (39)	2	12	110-019-037				
39	MOUNTING BASE, TRANSFORMER TYPE, 120V, SQUARE D, ZB2-BV3	26	156	110-050-019				
40	SURGE SUPPRESSOR, 15A, ISLATROL P/N IC+115	1	6	110-200-012				
41	DUPLEX RECEPTACLE, HUBBELL PN 5242-I	1	6	112-500-031				
42	HANDY BOX, STEEL CITY, P/N H58371-1/2	1	6	112-500-030				
43	HANDY BOX COVER, STEEL CITY, P/N 58C7	1	6	112-500-032				

BILL OF MATERIAL

PROJECT NAME :

FAYETTEVILLE, GA

BM NO: 1477.69.1 MANFACT L9-1477-PAN-1
LINE #31 - 48" FILTER CONTROL CONSOLE
CONTRACT NO: L9-1477
RELEASE DATE: 14 JUNE 2000

PREPARED BY: TAZ
APPROVED BY:

ITEM QUANTITY 6

MK NO.	DESCRIPTION	PER QTY	TOT QTY	PART NUMBER	VENDOR	P.O. #	UNIT COST	EXTD COST
44	PLC, MODICON P/N PC-A984-145 W/ 8K RAM	1	6	109-200-020				
45	DISCRETE INPUT MODULE, 16 PT, 120VAC, MODICON P/N AS-BDEP-218	2	12	109-200-027				
46	DISCRETE OUTPUT MODULE, 16 PT, 120VAC, MODICON P/N AS-BDAP-218	2	12	109-200-028				
47	ANALOG INPUT MODULE, 4 PT, MODICON P/N AS-BADU-206	2	12	109-200-042				
48	ANALOG OUTPUT MODULE, 4 PT, MODICON P/N AS-BDAU-204	1	6	109-200-043				
49	PRIMARY PLC RACK, MODICON P/N AS-HDTA-200	1	6	109-200-025				
50	SECONDARY PLC RACK, 5 SLOT, MODICON P/N AS-HDTA-201	1	6	109-200-030				
51	EEPROM, MEMORY CARD, 32K BYTE, MODICON, AS-MEEP-000	1	2	110-200-035				
52	DISKETTE STORAGE BOX, MODICON P/N AS-HBOX-201	1	2	109-200-036				
53	MODBUS PLUS TERMINATOR CONNECTORS, PN: AS-MBKT-185 (2 PER KIT)	1	1	109-200-039				
54	MODBUS PLUS LINE CONNECTORS, PN: AS-MBKT-085	1	6	109-200-038				
55	DATA ACCESS MODULE, PANEL-TEC P/N 1000-MT200 MOD	1	6	109-200-050				
56	DATA ACCESS MODULE ACCESSORIES, PANEL-TEC P/N 6000-6036	1	6	109-200-051				
57	POWER SUPPLY, 24 VDC , 2.5 AMPS, SOLA P/N SDN2.5-24-100	1	6	110-020-093				
58	DIGITAL INDICATOR, W/BLANK LENS & POWER SUPPLY, RED LION P/N IMP20160	5	30	110-020-087				
59	RATE SET STATION, LEEDS & NORTHRUP P/N 074825	1	6	110-020-075				
60	LOOP POWER SUPPLY, 24Vdc @65mA, ACTION P/N 9046	4	9	110-020-033				
61	SIGNAL ISOLATOR, , ACTION P/N Q406-0, (1) 4-20mA INPUT (1) 4-20mA OUTPUT	3	18	110-020-077				
62	RELAY SOCKET, 8 PIN TUBULAR, SCREW TERMINAL, SQUARE D P/N NR51	4	9	901207				
63	POWER DISTRIBUTION BLOCK, GOULD-SHAWMUT, 3 POLE, P/N 63163	1	6	110-005-250				
64	PDB SAFETY COVER, GOULD-SHAWMUT, 1 POLE, P/N 08530			110-005-251				
65	LEOPOLD COMPANY NAMEPLATE AND ASSOCIATED MOUNTING HARDWARE	1	6	107-002-106				

BILL OF MATERIAL

PROJECT NAME :

FAYETTEVILLE, GA

BM NO: 1477.69.1 MANFACT L9-1477-PAN-1
LINE #31 - 48" FILTER CONTROL CONSOLE
CONTRACT NO: L9-1477
RELEASE DATE: 14 JUNE 2000

PREPARED BY: TAZ
APPROVED BY:

ITEM QUANTITY 6

MK NO.	DESCRIPTION	PER QTY	TOT QTY	PART NUMBER	VENDOR	P.O. #	UNIT COST	EXTD COST
66	PHENOLIC NAMEPLATES AS PER ARRANGEMENT DRAWING	1	6	L9-1477-PARTS-1				
	SPARES							
67	RELAY, 4 POLE, SQUARE D, CLASS 8501, RS44P14V20	2	2	110-027-070				
68	RELAY, 2 POLE, SQUARE D, CLASS 8501, RS42P14V20	2	2	110-027-071				
69	SELECTOR SWITCH, 2 POSITION MAINTAINED, SQUARE D P/N ZB2-BD2 (31)	2	2	110-018-020				
70	SELECTOR SWITCH, 4 POS.MAINT'D., CONTACT ASS'Y., SQUARE D P/N 9003K2D004NA	2	2	110-018-094				
71	KNOB - XB2B STYLE, SQUARE D P/N ZBCZ1M12	2	2	110-018-095				
72	SELECTOR SWITCH ADAPTER, SQUARE D P/N KZ127	2	2	110-018-096				
73	SELECTOR SWITCH, 3 POSITION MAINTAINED, SQUARE D P/N ZB2-BD3 (32, 30, 30)	2	2	110-018-022				
74	SELECTOR SWITCH, 3 POS.SPRING RET. TO CENTER, SQUARE D P/N ZB2-BD5 (32)	2	2	110-018-021				
75	PUSHBUTTON OPERATOR, FLUSH HEAD, GREEN, SQUARE D ZB2-BA3 (31)	2	2	110-011-025				
76	PUSHBUTTON OPERATOR, EXT. HEAD, RED, SQUARE D ZB2-BL4 (ABORT BW) (31)	2	2	110-011-026				
77	CONTACT BLOCK , 1 N.C., SQUARE D P/N ZB2-BE102	2	2	110-005-087				
78	CONTACT BLOCK W/BASE, 1 N.O., 1 N.C., SQUARE D P/N ZB2-BZ105	2	2	110-005-085				
79	CONTACT BLOCK W/BASE, 2 N.O., SQUARE D P/N ZB2-BZ103	2	2	110-050-022				
80	PUSHBUTTON OPERATOR, ILLUMINATED, GREEN, SQUARE D ZB2-BW33 (34)	2	2	110-011-041				
81	MNT'G BASE, TRANS. TYPE, 120V, W/1 N.O., 1N.C. CONT. BLOCK, SQUARE D, ZB2-BW035	2	2	110-050-029				
82	PILOT LIGHT, GREEN, SQUARE D P/N ZB2-BV03 (38)	2	2	110-019-035				
83	PILOT LIGHT, RED, SQUARE D P/N ZB2-BV04 (38)	2	2	110-019-036				
84	PILOT LIGHT, AMBER, SQUARE D P/N ZB2-BV05 (38)	2	2	110-019-037				
85	MOUNTING BASE, TRANSFORMER TYPE, 120V, SQUARE D, ZB2-BV3	2	2	110-050-019				
86	LIGHT BULBS, SQUARE D P/N DL1CB006	10	10	110-002-024				